

OPERATING/INSTALLATION INSTRUCTIONS

(Translation)



Container Cleaning Device Jet Cleaner

TANKO®JX70-2 / TANKO®JX75-2
TANKO®JX80-2 / TANKO®JX80/70-2

Armaturenwerk Hötensleben GmbH

Schulstr. 5-6
D-39393 Hötensleben, Germany

Telephone: +49 39405 92-0
Fax: +49 39405 92-111
E-mail: info@awh.eu
Website: <http://www.awh.eu>

ID no.: 664BAJX0000EN - 2021/04 Rev. 0

NOTE



These instructions are an essential part of the device and must be available to operating and maintenance personnel at all times throughout its entire life cycle. The safety instructions contained therein must be observed.

If the device is resold, the instructions must always be transferred to the new owner.

Translation

The operating instructions must be written in an official European Community language acceptable to the manufacturer of the machinery in which the partly completed machinery will be assembled, or to his authorized representative. If any discrepancies arise in the translated text, the original operating instructions (German) must be consulted for clarification, or the manufacturer must be contacted.

These instructions and all figures contained therein are protected by copyright. Any use beyond the confines of copyright law is not permissible and liable to prosecution without the prior written approval of the publisher. This applies in particular to reproductions, translations, microfilming and storage and processing in electronic systems.

Contents

Contents	I
List of Figures	III
List of Tables	IV
Abbreviations and Units	V
1 Introduction	1
1.1 Means of Presentation	1
1.1.1 Explanation of Signal Words.....	1
1.1.2 Explanation of the Warnings	2
1.1.3 Pictograms and Symbols	4
1.2 Warranty and Liability.....	5
1.3 Product Names and Trademarks.....	5
1.4 Related Documents.....	5
2 Safety	6
2.1 Intended Use.....	7
2.2 Spare Parts, Replacement Parts and Accessories	11
2.3 Duties of the Operating Company	11
2.4 Requirements for Personnel.....	14
2.4.1 Personal Protective Equipment.....	15
2.5 Marking	16
2.5.1 Type Designation.....	16
2.5.2 Type Plate	16
3 Construction and Function	17
3.1 Construction.....	17
3.1.1 Special Designs.....	18
3.2 General Function Description	24
3.2.1 JX Function	26
3.3 Technical Data	27
3.4 Cleaning Media	30
4 Transportation and Storage	33
4.1 Packaging.....	34
4.2 Transportation	35
4.3 Storage	35
5 Installation	37
5.1 Safety Instructions for Installation	37
5.2 Installation	41
5.2.1 Interfaces.....	43
5.2.2 Installation Position	44

5.2.3 Installing the Device.....	45
5.3 Connection of the Actuator	49
5.3.1 Direction of Rotation of Cleaning Head	50
5.3.2 Speed Control	50
6 Commissioning.....	52
6.1 Safety Instructions for Commissioning.....	52
6.2 Functional Check/Trial Run.....	55
6.3 Switch-on Procedure.....	56
6.4 Operation.....	57
7 Maintenance	61
7.1 Safety Instructions for Maintenance	61
7.2 Switch-off Procedure.....	63
7.3 Removal.....	65
7.3.1 Removing the Device	66
7.4 Maintenance	68
7.4.1 Maintenance Intervals	71
7.4.2 Tools and Tightening Torques.....	74
7.4.3 Disassembling the Device	76
7.4.4 Assembling the Device.....	83
7.4.5 Notes on Cleaning.....	92
7.5 Spare Parts and Customer Service.....	94
7.5.1 Spare Parts for JX Standard.....	95
8 Faults.....	107
8.1 Safety Instructions for Troubleshooting	107
8.2 Faults and Remedial Action	109
8.3 What to do in Case of an Emergency.....	111
9 Decommissioning.....	112
9.1 Disposal.....	112
Index.....	114
Annexes	116
Notes	124

List of Figures

Figure 2.5-1: Type Plate Position.....	16
Figure 3.1-1: Basic Construction of the Device.....	17
Figure 3.1-2: Device without PC Version B0 (Examples)	18
Figure 3.1-3: Device with Linear Unit (Example)	19
Figure 3.1-4: Device with PC Version B1 (Examples).....	23
Figure 3.1-5: Device with PC Version B2 (Example).....	23
Figure 3.1-6: Downpipe Extension [DPE] (Example)	24
Figure 5.2-1: Device Interfaces	43
Figure 5.2-2: Installation Positions of the Device	44
Figure 5.2-3: Nozzle Position Stationary Device.....	47
Figure 5.2-4: Installation Opening of Mobile Device.....	48
Figure 7.3-1: Nozzle Position Stationary Device.....	68
Figure 7.4-1: Maintenance Points.....	72
Figure 7.4-2: Magnetic Coupling	76
Figure 7.4-3: Disassembly Motor Connection AG.....	77
Figure 7.4-4: Disassembly Axial Ball Bearing	78
Figure 7.4-5: Cleaning Head with Individual Parts (Example TANKO-JX75)	79
Figure 7.4-6: Adjustment Dimension for Magnet Carrier (Motor Side).....	83
Figure 7.4-7: Assembly Axial Ball Bearing	84
Figure 7.4-8: Magnetic Coupling	86
Figure 7.4-9: Cleaning Head with Individual Parts (Example for TANKO-JX75).....	87
Figure 7.4-10: Head AG JX70 (Screw Connection with the Downpipe AG).....	87
Figure 7.5-1: Downpipe AG with PC (JX75 and JX80)	95
Figure 7.5-2: Head AG JX70 (with Thrust Washer).....	97
Figure 7.5-3: Head AG JX70 (with Axial Bearing).....	97
Figure 7.5-4: Head AG JX70 + Adapter	97
Figure 7.5-5: Head AG JX75 (with Thrust Washer).....	98
Figure 7.5-6: Head AG JX75 (with Axial Bearing).....	98
Figure 7.5-7: Nozzle Holder AG JX70	101
Figure 7.5-8: Nozzle Holder AG JX75	101
Figure 7.5-9: Motor Connection AG JX70.....	103
Figure 7.5-10: Motor Connection AG JX80 and JX75.....	103
Figure 7.5-11: Downpipe Extension [DPE] AG	106

Figure 9.1-1: Spatial Positions of Gear Motors (Example SEW-EURODRIVE)	120
--	-----

List of Tables

Table 1.1-1: Overview of Signal Words.....	1
Table 2.1-1: Permissible Parameters for the Rest State	10
Table 3.1-1: Standards Overview of Process Connections	21
Table 3.3-1: Operating Parameters of the Device (Standard)	28
Table 3.3-2: Weight Comparison (Examples).....	29
Table 6.4-1: Time-limited Operation of the Device without Cleaning Medium	59
Table 7.4-1: Inspection and Maintenance Work	74
Table 7.5-1: Parts List for Downpipe AG (Standard)	96
Table 7.5-2: Parts List for Head AG without Nozzle Holder (Standard).....	100
Table 7.5-3: Parts List for Nozzle Holder AG (Standard)	102
Table 7.5-4: Parts List for Motor Connection AG JX70 (Standard)	104
Table 7.5-5: Parts List for Motor Connection AG JX75 and JX80 (Standard)	105
Table 7.5-6: Parts List for DPE AG JX (Standard).....	106
Table 8.2-1: Operating Faults – Cause and Remedy	110
Table 9.1-1: Overview of Air Motors	120

Abbreviations and Units

Abbreviations

ATEX	AT mosphère EX plosible; Synonym for the ATEX Directive of the European Union; comprises measures for explosion protection for potentially explosive atmospheres
AF	Width across flats [wrench size]
AG	Assembly group
Approx.	Approximately
ASSY	Assembly
ATO	According to order
AWH	Armaturenwerk Hötensleben GmbH
BetrSichV	Betriebssicherheitsverordnung (German Operational Safety Ordinance); ordinance concerning health and safety when using work equipment; German implementation of Directive 2009/104/EC of the European Parliament concerning the minimum safety and health requirements for the use of work equipment by workers at work
BS	British Standard
BSP	British Standard Pipe; British thread standard for pipe fittings
CIP	Cleaning in Place; a local (automated) cleaning process without dismantling plant parts. Denotes a procedure for cleaning processing plants, predominantly in sectors with particularly critical hygiene requirements, such as the pharmaceutical industry, food and beverage industry or biofuel plants.
DIN	Deutsches Institut für Normung e.V.; is a national standards organization in the Federal Republic of Germany; the standards of this organization are referred to as DIN standards.
DN	DIN nominal width
DP	Downpipe; in the context of these instructions, this colloquial term describes a line or connection in cleaning technology between a media connection [MC] and a cleaning head.
DPE	Downpipe extension; an extension to increase the usable installation length [LE] of the device.
EMC	Electromagnetic compatibility; synonym for the EMC directives of the European Union; includes measures for apparatus/equipment, a plant or a system intended to operate interference-free in an electromagnetic environment without causing electromagnetic interference itself.
EN	European Standard (Norm)
EPL	Protection level of the device (Equipment Protection Level)
etc.	and so on
FDA	Food and Drug Administration (US food and medication monitoring regulation authority)

if nec.	if necessary
IP	Individual part
ISO	International Organization for Standardization
JC	Jet cleaner
Jet	Cleaning jet In the context of these instructions, this colloquial term describes a cleaning jet from a jet cleaner [JC] used in cleaning technology.
JX	"JX" device series Jet cleaners with external actuator and internal gear unit.
LE	Usable installation length of the downpipe [DP]; the dimension corresponds to the distance from the lower edge of the process connection to the lower edge of the cleaning head.
L _{EX,8h}	Daily noise exposition level
L _{EXT}	Length of the downpipe extension [DPE]
L _{PA}	Emission noise pressure level at workplace
max.	maximum
MC	Media connection In the context of these instructions, this colloquial term describes the interface used in cleaning technology for supplying cleaning medium from the supply line to the device.
min.	minimum
NPT	National Pipe Thread; USA thread standard for pipe fittings
PC	Process connection In the context of these instructions, this colloquial term describes the interface used in cleaning technology for the connection to the process from the device to the container.
RC	Rinsing connection (optional); the rinsing connection is only used for removing or draining away the cleaning fluid (e.g. water) required for self-cleaning of the device in the area of the magnetic coupling, in the flow direction from the media connection [MC] to the rinsing connection [RC]. The connection is only recommended if the device is installed in a position that deviates from the standard.
SI	Système international d'unités; the most widely used international system of units for physical values
SN	Serial number
Stroke	Stroke For the purposes of these instructions, this term describes the path of a linear movement from point A to point B in a straight line for a moving component (e.g. cleaning head).
TRBS	Technische Regeln für Betriebssicherheit (German Technical Rules for Operational Safety); these rules specify the details of the "Betriebssicherheitsverordnung" (BetrSichV = German Operational Safety Ordinance) with regard to the identification and assessment of hazards and the derivation of suitable measures.

TRGS	Technische Regel für Gefahrstoffe (German Technical Rules for Hazardous Substances); these rules reflect the state of the art, occupational medicine and occupational hygiene as well as other sound scientific knowledge for activities involving hazardous substances, including their classification and identification.
v_{eff}	Effective vibration velocity
WA	Welded assembly
WP	Wear part

Terms

Stationary device:

The device remains fitted on the container for a long period, even during the production process.

Mobile device:

The device is mounted on and removed from the container several times in a short period, and can also be used for cleaning several containers.

Traversing device:

The device is moved dynamically within a defined stroke by means of an actuated linear unit (e.g. mechanical or pneumatic).

Units of Measure



The following indicated factors are intended for orientation and the conversion of the SI units to common units of measure for the American market.

bar	Unit of measure for pressure p [bar] All pressure [bar] specifications stand for overpressure [bar o] = positive pressure [bar g], unless expressly described otherwise (e.g. absolute pressure [bar a]). Conversion: 1 bar = 14.50376... psi [pound-force per square inch]
°C	Unit of measure for temperature T [degrees Celsius] Conversion from Celsius to Fahrenheit: $^{\circ}\text{C} \times 1.8 + 32 = ^{\circ}\text{F}$ [degrees Fahrenheit]
h	Unit of measure for time t [hours]
K	Unit of measure for temperature T and temperature differences ΔT [Kelvin] Conversion: 273.15 K = 0 °C
kg	Unit of measure for mass m [kilograms] Conversion: 1 kg = 2.20462 ... lb [Latin: libra; pounds]
l/min	Unit of measure for volume flow rate V [liters per minute] Conversion: 1 l/min = 0.06 m ³ /h [cubic meters per hour] 1 l/min = 0.26417 ... gpm (US) [gallons per minute (US)] 1 m ³ /h = 4.40286 ... gpm (US) [gallons per minute (US)]
lx	Unit of measure for illuminance E_v [lux]
m	Unit of measure for length l [meters] Conversion: 1 = 3.28083... ft [feet]
mm	Unit of measure for length l [millimeters] Conversion: 1 mm = 1/25.40005 in [inches] = 0.03937 in [inches]

Nm	Unit of measure for moment/torque M [newton meters] Conversion: 1 Nm = 0.737 lbft [pound-force feet]
rpm	Unit of measure for speed n [revolutions per minute] Conversion: 1 U/min = 1 rpm [revolutions per minute]
µm	Unit of measure for length l [micrometers]
MΩ	Unit of measure for electrical resistance R [Mega Ohm = 1 million ohms]
pS/m	Unit of measure for electrical conductivity of materials κ [picosiemens per meter]

1 Introduction

These operating/installation instructions (referred to hereinafter as the instructions) are a component of the device. They provide you with all the information required for smooth operation of the TANKO®JX jet cleaner (referred to hereinafter as the device).

The instructions must be read, understood, and applied by all persons employed to carry out installation and assembly, commissioning, maintenance, cleaning and troubleshooting on the device. This applies in particular to the listed safety instructions.

After studying the instructions, you will be able to

- install and operate the device safely,
- clean and service the device correctly and
- take the correct measures if a fault occurs.

In addition to these instructions, generally applicable, statutory and other binding regulations for the prevention of accidents and for environmental protection in the country of use must also be observed.

The instructions must be kept at the location of use of the device so that they are available in legible condition at all times. If the device is resold, the instructions must always be transferred to the new owner.

Download the instructions, if necessary, from the website <http://www.awh.eu>.

1.1 Means of Presentation

1.1.1 Explanation of Signal Words

The warnings are introduced with a signal word which describes the extent of the hazard. The meaning and their classification in case of hazardous situations are explained in the following overview.

Signal Word	Meaning	Consequences of Failure to Observe
⚠ DANGER	Hazard with a high level of risk	Death or severe physical injury
⚠ WARNING	Hazard with a medium level of risk	Death or severe physical injury
⚠ CAUTION	Hazard with a low level of risk	Minor or moderate physical injury
NOTE	Hazard with a low risk	Risk of material damage

Table 1.1-1: Overview of Signal Words

1.1.2 Explanation of the Warnings

Section-related Warnings

The section-related warnings apply not only to one particular action, but rather to all actions within a section. In addition, the pictograms and symbols indicate a general or specific danger.



DANGER

This warning warns of a hazard with a high level of risk!

Failure to observe it can lead to death or severe physical injury.

- *Measure(s) to prevent the danger*



WARNING

This warning warns of a hazard with a medium level of risk!

Failure to observe it can lead to death or severe physical injury.

- *Measure(s) to prevent the danger*



CAUTION

This warning warns of a hazard with a low level of risk!

Failure to observe it can lead to minor or moderate injury.

- *Measure(s) to prevent the danger*

NOTE

This warning warns of a hazard with a minor level of risk!

Failure to observe it can lead to material damage.

- *Measure(s) to prevent the danger*

Embedded Warnings

The embedded warnings apply to specific actions and are integrated directly into the action before the specific action step.

The embedded warnings are structured as follows.

⚠ SIGNAL WORD Type and source of the danger

Possible consequences in case of failure to observe

- Measure(s) to prevent the danger

Further Means of Presentation

INSTRUCTION

This note contains specific safety-relevant instructions and/or work steps for operational procedures and switch-off processes that are to be strictly complied with.

Non-compliance prevents operational safety, thus leading to hazards.



The "Info" symbol provides useful information, additional tips and recommendations.

- Texts which follow this mark are bulleted lists.
- Texts which follow this mark describe measures for prevention of the danger.
- 1. Texts which follow this numbering describe the first step of a task, followed by further numbered steps which have to be performed in the specified order.
- a) Texts which follow this lettering as a subitem of a numbering (e.g. 1) describe the first step of a task for a higher-level task, followed by further lettered steps which have to be performed in the specified order.
- (1) Numbers in brackets reflect the item numbers in figures or parts lists.
- " " Texts in quotation marks are (direct) quotes from documents (e.g. directives or standards) or words, word groups and parts of a text with a special meaning.

Important, significant information is shown with additional **bold type**, *in italics* or CAPITAL LETTERS for emphasis of individual words or phrases.

1.1.3 Pictograms and Symbols

The following pictograms and symbols are used as a supplementary measure in these instructions to clarify the sources of dangers and measures. They can appear at all levels of danger.



Warning about electrical voltage



Warning about potentially explosive atmosphere



Warning about hand injuries



Warning about a hot surface



Warning about corrosive substances



Warning about magnetic field



Warning about automatic startup



Warning about trapping/entanglement hazard



Warning about substances which are a water hazard



People with pacemakers must keep away



Unauthorized access prohibited



Wear protective work clothing



Wear safety shoes



Wear protective gloves



Wear safety goggles



Wear a hard hat



Wear hearing protection



Wear a welding mask



Isolate from voltage before work



Obey instructions



Protective grounding required



Secure against power being switched back on



Return for recycling

1.2 Warranty and Liability

The commitments agreed in the contract of supply and delivery, the general terms and conditions and the terms of delivery of Armaturenwerk Hötensleben GmbH (referred to hereinafter as AWH) and the statutory regulations valid at the time the contract was concluded shall apply.

Warranty and liability claims in case of personal injury and material damage shall be excluded, in particular if these can be attributed to one or more of the following causes:

- Improper or incorrect use of the device,
- Improper assembly and installation, commissioning, operation and maintenance of the device,
- Failure to observe the notes in the instructions regarding assembly and installation, commissioning, operation and maintenance of the device,
- Constructional modifications to the device (conversions or other modifications to the device must not be made without previous written approval from AWH. In case of infringement, the device will lose its EU conformity and the operating authorization.),
- Use of spare parts that do not comply with the specified technical requirements,
- Improperly performed repairs,
- Disasters, the effects of foreign objects and force majeure.

Disclaimer

AWH reserves the right to make alterations to this document at any time without prior notice. AWH provides no guarantee (neither expressed nor implied) with regard to all information in this document, including but not limited to the implied guarantee of merchantability and suitability for a particular purpose. Furthermore, AWH does not guarantee the correctness or completeness of information, text, graphics or other parts in this document.

1.3 Product Names and Trademarks

The product names and trademarks included in these instructions are brands or registered trademarks of the respective owners.

TANKO® and AWH® are registered trademarks of Armaturenwerk Hötensleben GmbH.

1.4 Related Documents

The following documents may contain supplementary information for these instructions:

- Manufacturer's declarations and/or certificates of conformity
- Certificates
- Additional documents for any attached or upstream components, e.g. drawings, technical data, information on accessories etc.
- Supplements to these instructions (e.g. special designs)
- AWH catalog, product data sheet

2 Safety

The device has been built in accordance with state-of-the-art technology and the recognized safety rules. Nevertheless, use of the device may pose a danger to the life and limb of the user and third parties or a risk of impairments to the device and other objects of material value as a result of its function.

The following basic safety instructions are intended to prevent injury to personnel and material damage. The operating company must ensure that the basic safety instructions are observed and adhered to.

These instructions contain basic notes on installation, operation, maintenance and servicing of the device which must be complied with.

Anyone involved in installation, operation, maintenance and servicing must have read and understood these instructions.

The safety systems and safety instructions described in these instructions must be adhered to.



WARNING



Failure to comply with these instructions, incorrectly performed installation and repair work or incorrect operation could lead to malfunctions on the device and to dangerous situations!

There is a risk of death or severe physical injury.

- *All work performed on the device must be carried out only by a specialist and in compliance with
 - the corresponding detailed operating and installation instructions,
 - the warnings and safety signs on the device,
 - the regulations and requirements specific to the plant and
 - the national/regional regulations for safety and the prevention of accidents.*
- *Never install damaged devices or components.*



The figures in these instructions are intended to provide basic understanding, and are primarily representations of the principles involved. They may differ from the actual design of the device.



For maintenance and repair, we recommend a training course provided by the manufacturer or a person authorized by the manufacturer.



If you have questions or doubts about handling the cleaning device, please contact AWH.

Built-in Safety Systems

The built-in safety devices used by the higher-level plant in which the device is installed are to be tested at regular intervals.

WARNING

Dangerous situations arising from changing or disabling safety devices!

Only functional safety devices can ensure safe operation and prevent inadmissible operating conditions.

Changing or disabling safety devices can lead to unpredictable and dangerous situations. There is a risk of death or severe physical injury.

- *Disabling the safety devices or changing the way they operate is strictly prohibited.*

2.1 Intended Use

DANGER



Danger from fire/explosion when using the device in a potentially explosive atmosphere!

Use of the device in an Ex area (potentially explosive atmosphere) is PROHIBITED.

There is a risk of death or severe physical injury.

- Follow the information on the **type plate** of the device (see [Section 2.5.2 Type Plate](#)) and the **relevant operating instructions**.

WARNING

Risk of hazardous situations caused by use other than the intended use and/or other types of use of the device!

There is a risk of death or severe physical injury.

- *Only use the device for the intended use.*
 - *Only ever use the device in accordance with the specifications contained in these instructions and the specifications on the device's type plate.*
 - *All the specifications in these instructions must be adhered to at all times.*
 - *Always keep the operating instructions at the location where the device is used.*
 - *Keep all signs on the device in legible condition.*
 - *Only use original spare parts.*
- *Modifications or conversions of the device are NOT permitted.*

The TANKO-JX is a cleaning device with an external actuator and belongs to the group of jet cleaners. The device is used for cleaning the interiors of containers with and without installed equipment.

For the purpose of these instructions the word "container" refers to **closed** tanks, silos, barrels, containers, pipes, and similar, that are provided with an outlet that ensures that the supplied cleaning medium can drain freely.

Cleaning Media

Only sprayable fluids that meet the requirements in [Section 3.4 Cleaning Media](#) may be used for cleaning.

The device was developed, engineered and built exclusively for industrial and commercial use. It must not be used for private use.

The device is constructed so that it can be operated safely within the specified technical parameters (see [Section 3.3 Technical Data](#)).

In all cases, the operating company must check whether the device is suitable for its application.

Locations for containers in which the device is to be installed are usually closed spaces. In different setups, the operating company must ensure the protection of the device from harmful weather and environmental influences while maintaining the specified application limitations/conditions (see [Section 3.3 Technical Data](#)).

In the process, the following must always be observed:

- Only operate the device when installed in a closed container.
- Never direct the cleaning jet or torrent from the device at persons.
- Protect the device from freezing (e.g. risk of frost from possible residual water).
- Use a suitable filter system in the supply line for the cleaning medium.
- Operate the device only within the approved parameters (see [Section 3.3 Technical Data](#)). If necessary, appropriate monitoring and limiting systems (e.g. for pressure and temperature) should be implemented.
- Only cleaning media that are compatible with the materials of the device may be used (see [Section 3.4 Cleaning Media](#)).
- The installation position of the device (see [Section 5.2.2 Installation Position](#)).
- The device may generate vibrations when cleaning the container. Any other vibrations must be avoided (see [Section 7.4.1 Maintenance Intervals](#)).

**WARNING*****Danger from incorrect use of materials/media!***

The materials/media to be used for the intended operation of the device are procured and utilized by the operating company of the device.

If unsuitable materials/media are selected, strong chemical reactions could lead to fatal injury or severe physical injuries.

- *The proper selection and treatment of these materials/media is solely the responsibility of the operating company.*
- *When selecting the materials/media, make sure that the permitted technical parameters of the device are NOT exceeded.*
- *The cleaning agents and media must be approved for all of the materials of the device (e.g. washers, bushings) and for the substances in the container to be cleaned which come into contact with them.*
- *Adhere to the specified chemical limits for use in the material data sheets.*
- *Adhere to the safety data sheets provided by the manufacturers of the materials and media, in particular for hazardous substances:*
 - *Comply with the hazard and disposal instructions.*
 - *Set out protective measures and compile operating instructions for hazardous substances.*
 - *This also applies to hazardous substances that may develop during work processes.*

Refer to the order confirmation/parts list from AWH for the materials used in the device.

When using the device, it is necessary to distinguish between the following operating states.

Operating State – Cleaning Process (cleaning > cleaning medium is sprayed and cleaning head rotates)

Process conditions

- Pressure in the container: 0 to 0.5 bar (0 to 7.25 psig)
- Temperature of the cleaning medium: +5 °C to +95 °C
- Ambient temperature in the container to be cleaned: +5 °C to +95 °C

Operating State – Rest State (NO cleaning > cleaning medium is NOT sprayed and cleaning head is stationary)

If the device is in the rest state or is NOT being operated, then the supply line of the cleaning medium must be closed off as close as possible to the media connection [MC] of the device by means of an appropriate shut-off device (e.g. slide valve, flap, tap or valve) so that the spread of gases and vapors or an unintentional supply of media is prevented. There may only be an open connection for the cleaning medium from the supply line (pump) to the medium connection [MC] during the cleaning process.

The permissible parameters for the rest state depend on the design of the device (e.g. material of the parts) and must be observed during production or manufacturing processes before or after cleaning.

Rest state	
Pressure in the container	0 to 0.5 bar (0 to 7.25 psig)
Ambient temperature	(O-ring material FKM, FFKM or FKM+FEP coated)
– Inside the container	-15 °C to +110 °C
– Outside the container	-15 °C to +40 °C
Ambient temperature	(O-ring material, EPDM)
– Inside the container	-20 °C to +110 °C
– Outside the container	-20 °C to +40 °C
NOTE Risk of frost!	Empty the device at temperatures below freezing.

Table 2.1-1: Permissible Parameters for the Rest State

If an overpressure or underpressure is required in the container during the rest state for other processes, then an additional hazard or risk assessment must be prepared for the individual case regarding the resulting hazards in order to specifically demonstrate the suitability of the device used. In particular, the process connection [PC] and the media connection [MC] as well as the shut-off fitting for the cleaning medium must be considered here.

This device is intended exclusively for the purpose outlined above. Any other use beyond that described here or any conversion of the device without a written agreement with the manufacturer is considered IMPROPER use.

The manufacturer accepts NO liability for damage arising from such improper use. The operating company bears the sole risk.

Non-Intended Use

Operation of the device without cleaning medium is not permitted and is only permitted for a limited time for certain situations without cleaning medium (see [Table 6.4-1: Time-limited Operation of the Device without Cleaning Medium](#)).

The device is **NOT suitable** for the following applications:

- The device is NOT suitable for ATEX applications.
- The device is NOT suitable for private use.
- The device is NOT suitable for use outside of containers.
- Holding the device with your hand during operation is PROHIBITED.
- The device must NOT be immersed in the product of the production process (NOT even partially). This could cause the product to enter into the device. The spray holes may become blocked. The free movement of the actuator could be obstructed.

The device must not be put into operation until it has been assured that all the safety devices are fully functional and the plant in which the device is installed meets the safety requirements of all relevant European directives (e.g. the Machinery Directive).

2.2 Spare Parts, Replacement Parts and Accessories



WARNING

Risk of damage, malfunction or complete failure of the device!

Incorrect or faulty spare/replacement parts and accessories put the functional safety and reliability of the device at risk. This can result in failure of components or a device malfunction, as well as material damage and consequential damage.

There is a risk of death or severe physical injury.

- *Only use the manufacturer's original spare parts.*

We expressly draw attention to the fact that spare parts and accessories NOT supplied by AWH have NOT been checked or approved by AWH. The installation and/or use of such products could therefore, under certain circumstances, result in changes with negative results to the properties of the device specified by its design and the higher-level plant.

AWH is not liable for any damage arising from the use of non-original parts or non-original accessories. Standard parts can be obtained from specialist dealers.

A list of spare parts is provided in [Section 7.5 Spare Parts and Customer Service](#).

2.3 Duties of the Operating Company

The device is used in the commercial sector. The operating company is thus subject to the legal obligations regarding occupational safety.

In the EEA (European Economic Area), the national implementation of the Framework Directive 89/391/EEC on the introduction of measures to encourage improvements in the safety and health of workers at work, as well as the associated individual directives shall be observed and complied with in their current valid versions.

Of particular importance in this connection is Directive 2009/104/EC concerning the minimum safety and health requirements for the use of work equipment by workers at work.

As a basic rule in Germany, the Operational Safety Ordinance (BetrSichV) must be observed.

In other countries, the respective national guidelines, statutes and country-specific regulations regarding occupational safety and accident prevention must be complied with.

At the same time, the following, non-exhaustive instructions apply in particular:

- The operating company must ensure that the device is used only as intended (see [Section 2.1 Intended Use](#)).
- The operating company must keep informed of the locally applicable occupational health and safety regulations and, in addition, use a risk assessment to determine the hazards resulting from the specific working conditions at the location of use of the device. These must then be implemented in the form of operating instructions for the operation of the device.
- When using hazardous materials, protective measures must be specified in accordance with the safety data sheets and operating instructions shall be compiled for hazardous materials. Personnel must be instructed accordingly. This also applies to hazardous substances that may develop during work processes.

- A continuous risk assessment must be carried out for workplaces, including temperature conditions for the medium and the place of use (falling). The measures are to be defined in operating instructions. Personnel must be instructed accordingly.
- Supervisors must monitor compliance with the measures specified in the operating instructions.
- Throughout the entire operating period of the device, the operating company must check whether the operating instructions it has compiled reflect current legislation requirements and adapt them as necessary.
- The operating company must clearly regulate and specify the responsibilities of personnel (e.g. for operation, maintenance and cleaning).
- The operating company must allow only sufficiently qualified and authorized personnel to work on the device.
- The operating company must ensure that all employees handling the device have read and understood the instructions.
Furthermore, it must provide personnel with training at regular intervals with certification and inform them of the hazards.
- The operating company must provide sufficient workplace lighting at the plant in accordance with the locally applicable regulations for occupational health and safety, in order to prevent hazards occurring as a result of poor lighting.
- The operating company must provide personnel with personal protective equipment and make sure that this is used (see [Section 2.4.1 Personal Protective Equipment](#)).
- The operating company must make sure that the danger area of the higher-level plant in which the device is installed is not accessible to unauthorized persons.
- The operating company must make sure that no one is permitted to work on the device whose ability to react is impaired by drugs, alcohol, medication or similar.
- The operating company must take appropriate measures to inform groups of persons who are not intended to come into direct contact with the device (e.g. visitor groups) about the potential dangers involved.
- The operating company is responsible for making sure that the device is only ever operated in perfect condition.
- Wherever high pneumatic pressures occur, there is a possibility of sudden failure of or damage to the lines and connections. This poses a hazard. The operating company must instruct operating and maintenance personnel at least once a year on the possible hazards.
- The constructor of the overall plant must install the switching and safety devices required for setting up, inspection, shutting down (including emergency shutdown), operation, maintenance, cleaning and repair.
- The operating company must design the disconnection of the energy sources on the higher-level plant technically in such a way that the [Switch-off Procedure](#) described in [Section 7.2 Switch-off Procedure](#) can be adhered to.
- The operating company must define and adhere to the intervals for inspections and control measures in accordance with the environment and media used.

- The operating company must provide fire safety devices, e.g. the appropriate quantity of suitable hand-held fire extinguishers of the appropriate size, in easily accessible places and provide employees with training in fire safety.
- Warnings in the documentation of externally supplied assembly groups must be adhered to and incorporated into the risk assessments for the specific workplace.
- For installation of the device in a plant, the operating company must guarantee safe access using steps, platforms and rails in accordance with EN ISO 14122-1-3.

Connections:

Before operating the machine with the device, the operating company must make sure that the local regulations are observed for assembly, installation and commissioning, if these tasks are performed by the operating company.

- Hydraulic connections must fulfill the requirements of EN ISO 4413.
- Pneumatic connections must fulfill the requirements of EN ISO 4414.
- Electrical connections must fulfill the requirements of EN 60204-1.

2.4 Requirements for Personnel

The device must only be operated, maintained and repaired by persons with the appropriate qualifications. These persons must be familiar with the instructions and act in accordance with them. The respective authorizations for personnel must be clearly defined.

The following qualifications are designated in the instructions for various fields of activity:

Expert/Specialist Personnel

An expert is a person whose professional training, knowledge, and experience and knowledge of the relevant standards and regulations enables them to carry out work on the device and identify and prevent potential risks independently.

Instructed Person

An instructed person has been instructed and, if necessary, trained by the operating company or an expert in a briefing on the assigned tasks and possible hazards in the event of improper actions, and instructed on the necessary safety devices and protective measures.

Only personnel with the following expertise are permitted to perform work on the device:

- **Assembly/disassembly:** Industrial mechanic or comparable vocational qualification, practical experience in the assembly/disassembly of devices
The person must be familiar with the construction, mechanical installation, maintenance and troubleshooting of the device, and have the following qualifications:
 - Vocational training and final qualification in the field of mechanics (e.g. mechanic or mechatronics technician)
- **Welding work:** Welder qualification in pipeline engineering or similar apprenticeship
- **Electrical work:** Electrician; person with appropriate specialized apprenticeship, knowledge and experience, enabling them to identify and prevent risks which may be caused by electricity
The person must be familiar with the electrical installation, commissioning, troubleshooting and repair of the device and have the following qualifications:
 - Vocational training and final qualification in electrical engineering (e.g. electrician, electronics engineer or mechatronics technician)
 - Several years of vocational experience in the field of electrical engineering
- **Cleaning:** Instructed person

Work performed in the other areas, i.e. **transportation, storage, operation and disposal**, must be performed exclusively by personnel who have received suitable instruction.

All of the personnel listed above must wear protective clothing in accordance with their respective activities.

2.4.1 Personal Protective Equipment

Personal protective equipment must be used in accordance with the respective task when working on the device in order to minimize health hazards.



Protective work clothing

Protective work clothing is tight-fitting work clothing with low resistance to tearing, with tight-fitting sleeves and without protruding parts. It is mainly used for protection against becoming entangled in moving components. Do not wear any rings, necklaces or other jewelry.



Safety shoes

Wear slip-resistant safety shoes for protection against heavy, falling objects or for protection against slipping on slippery surfaces.



Protective gloves

Wear protective gloves to protect your hands against friction, grazes, getting pricked or deep cuts and for protection against coming into contact with hot surfaces or chemical substances.



Protective goggles

Wear protective goggles for protection against media escaping at high pressure and against flying objects.



Hard hat

Wear a hard hat for protection against falling or flying objects.



Hearing protection

Wear hearing protection to protect yourself from an increased noise level (≥ 85 dB(A)).



Welding mask

Wear a welding mask to protect against damage to the eyes or skin caused by the welding arc and to protect against burns caused by flying particles during welding.

Personal protective equipment must be provided by the operating company in accordance with the valid requirements. Furthermore, both the national regulations and, if necessary, the internal instructions from the operating company must be observed.

2.5 Marking

2.5.1 Type Designation

Example: Jet cleaner

- 1) Brand of the cleaning devices: **TANKO**
- 2) Type/series: **Jet with eXternal actuator**
- 3) Size: **Cleaning head ≈ 75 mm**
- 4) Variant: **encapsulated magnetic coupling**
- 5) Installation length [LE]: **≈ 500 mm**

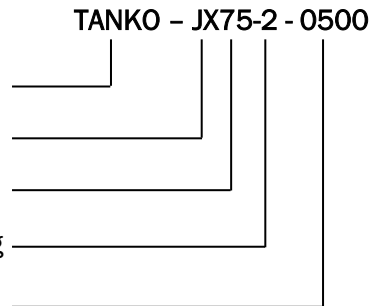

2.5.2 Type Plate

The marking is applied to the device according to the following figure.

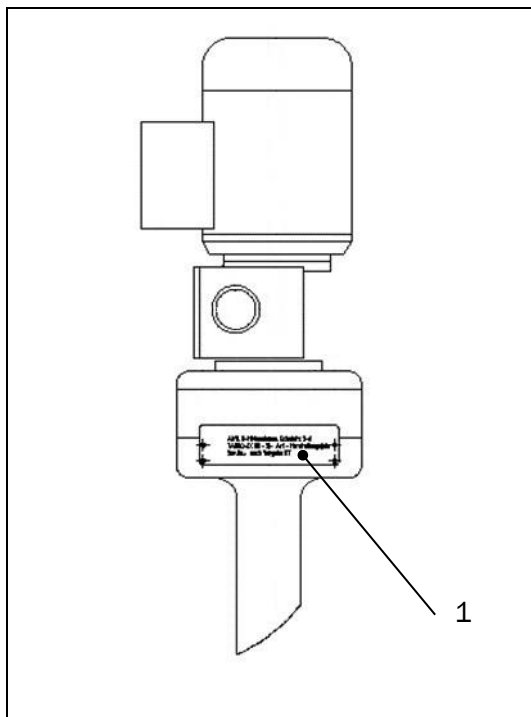

1 Device type plate

In case of inquiries, the data on the type plate of the device are important for proper and speedy processing:

- Manufacturer address
- Type designation
- Year of manufacture
- Article number
- Serial no. [SN]

Figure 2.5-1: Type Plate Position



The labeling or writing on the type plate of the device must be permanently visible and legible so that the device can be unambiguously and fully identified throughout its entire life cycle.

3 Construction and Function

The jet cleaners of the TANKO-JX series combine strong cleaning power with a particularly economical use of cleaning medium.

Thanks to the separate external actuator, the rotational movement of the cleaning head is independent of the volume flow rate of the cleaning medium. Therefore, the parameters for good cleaning performance, such as rotation speed and throughput, can be easily adapted to the cleaning requirements. Cleaning is performed by a 360° orbital spray pattern.

3.1 Construction



The TANKO-JX series devices are essentially identical in construction. The design is primarily determined by the different connections and the number and sizes of the nozzles. This results in the differing construction sizes and performance parameters of the devices, e.g. volume flow rate and cleaning radius. The cleaning of differently sized containers is possible due to the differing ranges of the cleaning jet.

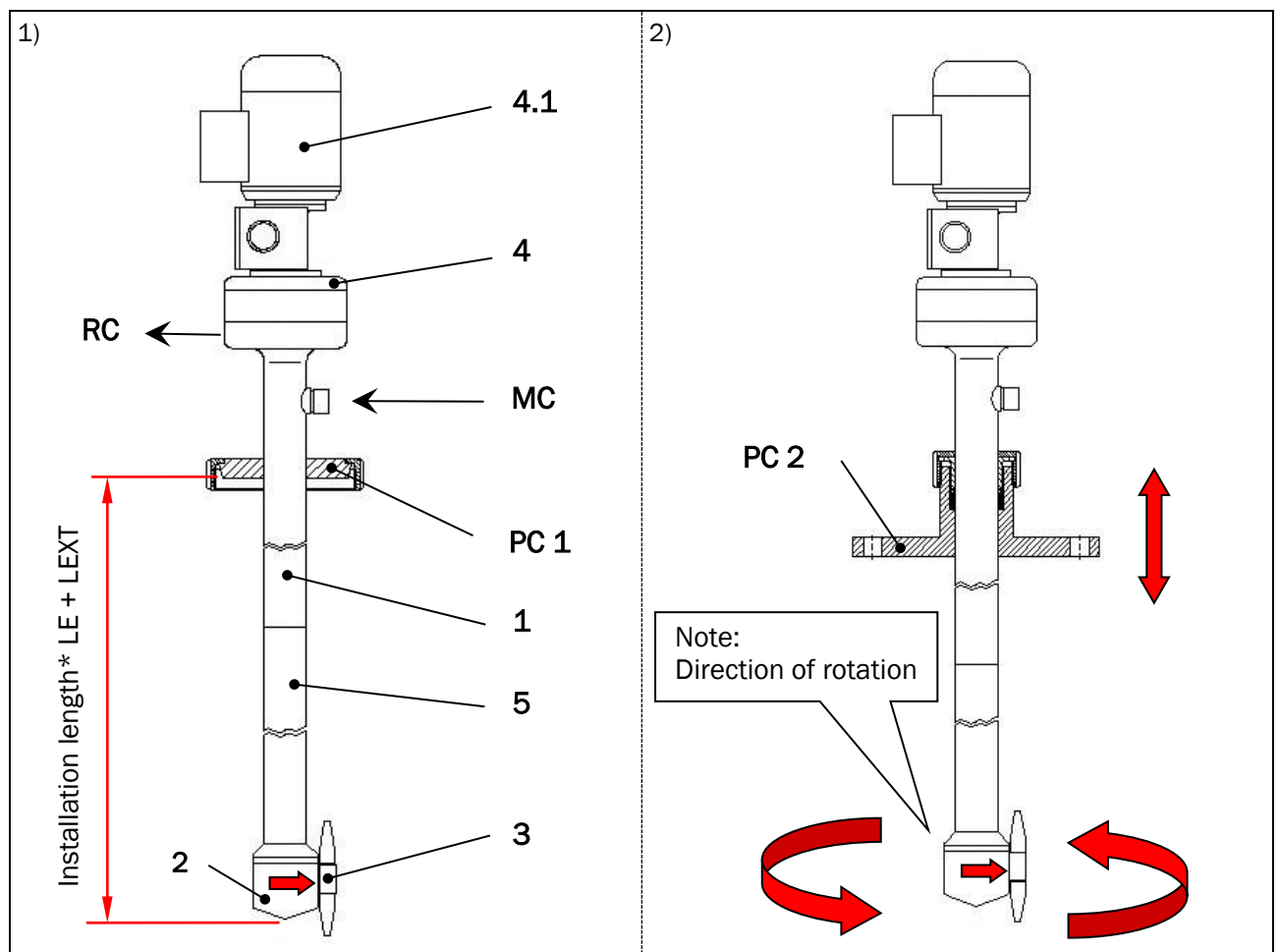

Figure 3.1-1: Basic Construction of the Device

* For installation length, see [Table 3.3-1: Operating Parameters of the Device \(Standard\)](#)

The jet cleaners (with external actuator) type TANKO-JX consist of the following assembly groups:

- 1 Downpipe AG (with magnet carrier)

PC 0 = without process connection	> not shown in the figure (special design)
PC 1 = Process connection 1	> with downpipe [DP] permanently welded
PC 2 = Process connection 2	> can be moved on downpipe [DP] (special design)
MC = Media connection	> with downpipe [DP] permanently welded
RC = Rinsing connection	> optional
- 2 Head AG without nozzle holder
- 3 Nozzle holder AG
- 4 Motor connection AG (with magnet carrier)
- 5 Downpipe extension assembly = DPE AG > optional (JX75 and JX80 only)

3.1.1 Special Designs

For the different designs of the special devices, in particular the media [MC] and process connections [PC] as well as for the diversity of practical applications, it is NOT possible for AWH to provide all technical information here generally for each individual case. For example, the permissible pressures for devices whose connections are made via an adapter or for special devices in other designs (e.g. flange, tri-clamp, etc.) may differ from the standard devices.

It is for this reason that AWH can offer the operating company, **solely as a precautionary measure, a few points of reference and notes** to be observed and to be integrated into the operating company's hazard and risk assessments.

Version B0 - Device without Process Connection [PC]

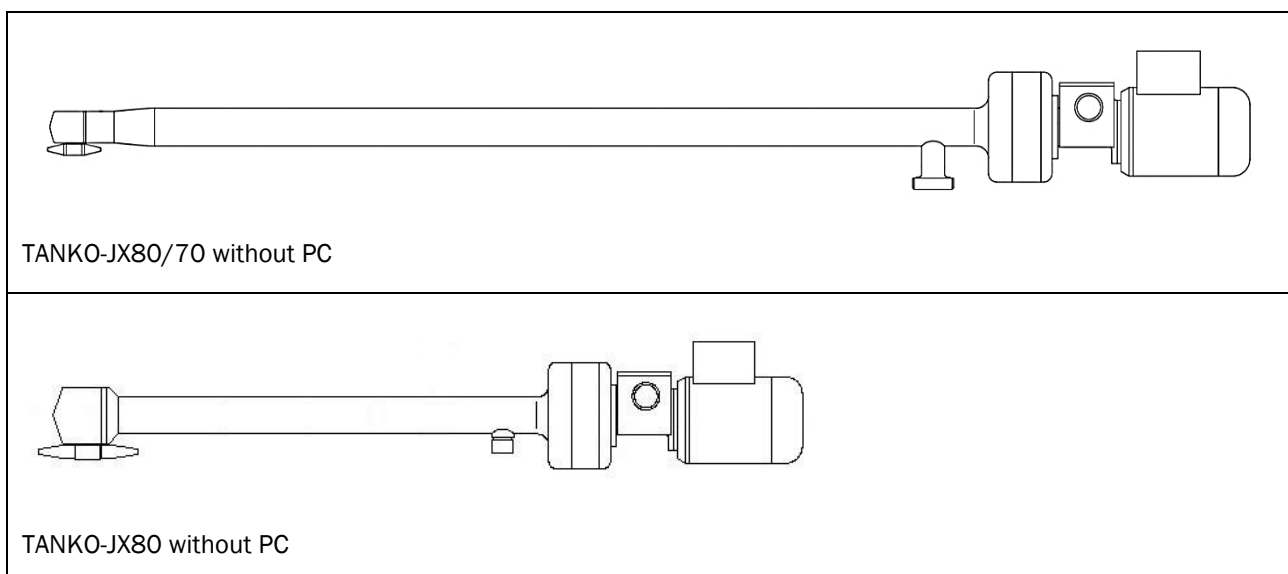

Figure 3.1-2: Device without PC Version B0 (Examples)

Basically, these devices must NOT be operated as intended without a proper connection of the downpipe [DP] to the installation opening of the tank in the area between the cleaning head and the media connection [MC]. Devices without process connection [PC] are a special design of the special devices. These devices are used where there are special technical requirements for connecting the devices to the container or where automation of cleaning processes is planned. Operating companies

take direct responsibility for the design of the necessary components for connection and for automation.

One possible application is, for example, the retraction and extension of the devices with a linear unit (see [Application Example – Version B0](#)).

When using these devices, the process connection must ensure the required separation of the areas "container inside"/"container outside". The connection must be solid and technically leakproof. Uncontrolled lowering of the device into the container must be prevented.

Instructions must be observed on use of the devices within the effective range of internal fittings in [Section 3.2](#) and on installation on interface C in [Section 5.2.3](#).



The following are required for the safe operation and use of devices without process connection [PC]:

- the system for sealing or closing the installation opening of the container,
- the structural design for fastening (e.g. for a linear unit),
- the functional requirements of the control system (e.g. manual or automatic) and
- all other conditions for integrating the device into the cleaning system

in the context of an additional hazard or risk assessment. The operating company is responsible for implementing the resulting measures.

Application Example – Version B0:

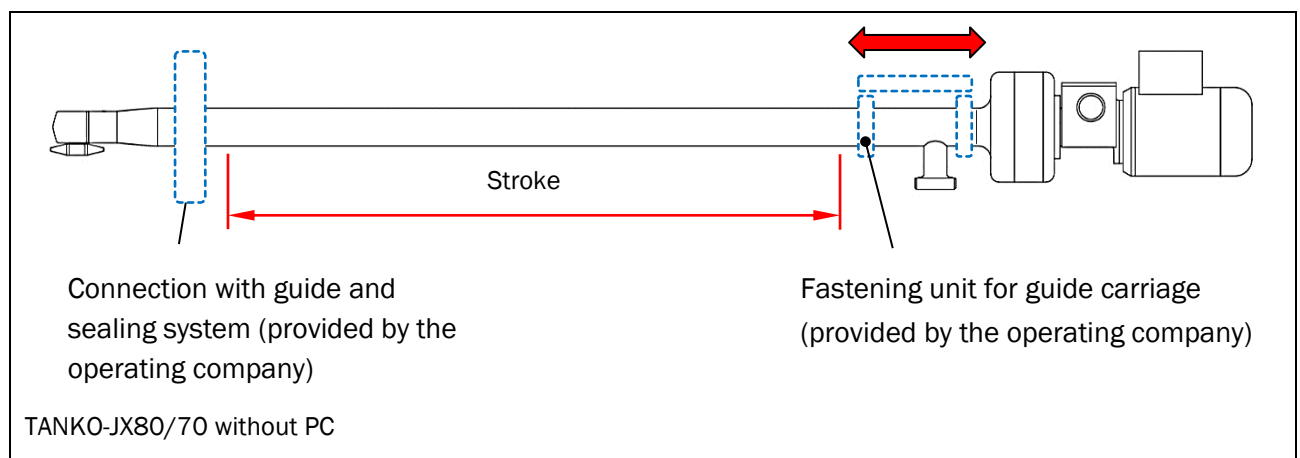

Figure 3.1-3: Device with Linear Unit (Example)

As a rule, a completely actuated unit consists of a guide system, an actuator unit (e.g. servo motor) and a control system. The linear unit can be actuated mechanically, pneumatically, hydraulically or electrically.

To move the device dynamically with a linear unit within a stroke, the device is mechanically attached to the guide carriage of the linear guide by means of a fastening unit on the downpipe [DP] in the area of the media connection [MC]. To avoid a high load on the linear actuator, the supply lines of the energy supply (e.g. for the electrical and media connection), should be kept as short as possible and, if necessary, supported (e.g. energy chain).

Avoid jerky movements when moving the device and during cleaning. It must be ensured that there are no foreign objects in the moving area of the device and the linear guide and that no persons are present and/or able to reach into this area during movement.

An automatically controlled linear movement of the cleaning head makes it possible to optimize the cleaning process and reduces cleaning times. Different sequences for the cleaning process can be implemented with one control system.

During cleaning, the cleaning head can move within the possible stroke and

- moves to various specified positions and/or
- moves slowly over a specified area (back and forth).

In the rest state, the cleaning head is

- Outside the container
The installation opening of the container is sealed and locked via a separate fitting (e.g. slide valve)
or
- Inside the container
The container is sealed and locked directly via a special sealing system between the downpipe [DP] of the device and the installation opening of the container.

B1 Version - Device with Welded Process Connection [PC]

The devices are equipped with a welded process connection [PC]. The position of the cleaning head in the container is thus determined by the installation length [LE] and can NOT be changed. In deviation from the standard designs, depending on the installation opening of the container and the size of the cleaning head, further permanently welded connections in different sizes and standardized nominal widths are possible.

Standard	Designation	Remarks
DIN 11851	Stainless steel fittings for the food and chemical industry	Screw pipe connections for expanding and welding
DIN 11853-1	Stainless steel fittings for the food and chemical industry	Part 1: Hygienic screwed pipe connection, short type
DIN 11853-2		Part 2: Hygienic flange connection, short type
DIN 11853-3		Part 3: Hygienic clamp connection, short type
DIN 11864-1	Fittings of stainless steel for the aseptic, chemical and pharmaceutical industry	Part 1: Aseptic screwed pipe connection, standard type
DIN 11864-2		Part 2: Aseptic flanged pipe connection, standard type
DIN 11864-3		Part 3: Aseptic clamp connections, standard type
DIN 32676	Fittings for the food, chemical and pharmaceutical industries	Clamp connections for stainless steel tubes Weld-on type
EN 1092-1	Circular flanges for pipes, valves, fittings and accessories	Part 1: Steel flanges, PN designated
DIN EN 14420-7	Hose fittings with clamp units	Part 7: Cam locking couplings Remark: Quick coupling with SELF-locking device (e.g. SAFLOK® compatible with A-A-59326B (MIL-C-27487) standardized).

Table 3.1-1: Standards Overview of Process Connections

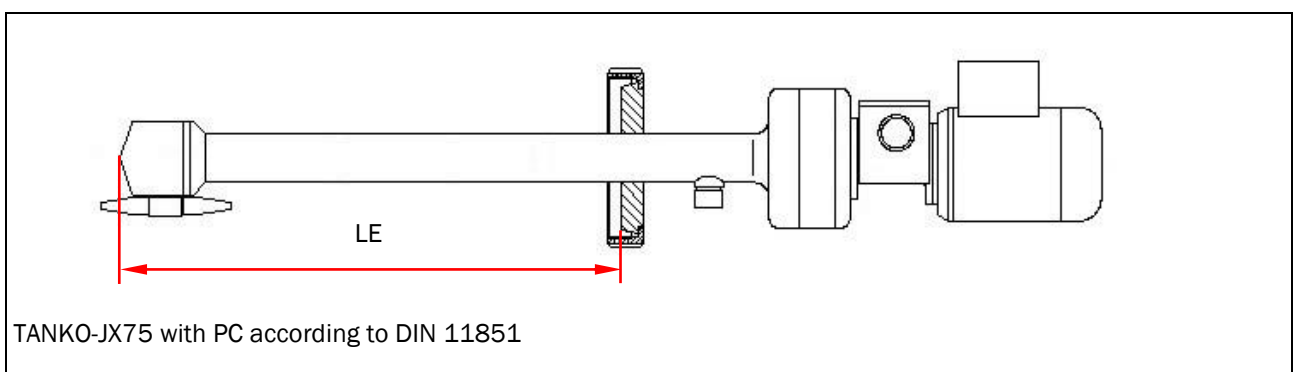

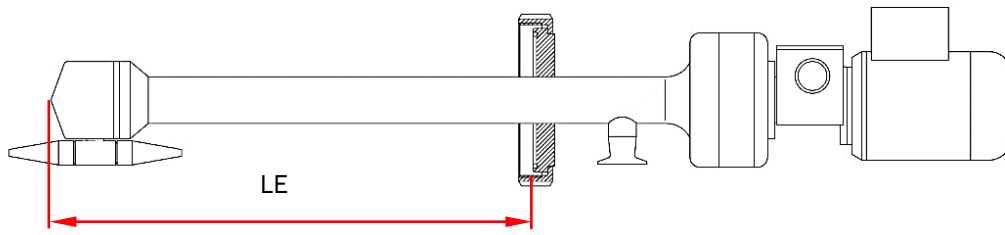

TANKO-JX80 with PC according to DIN 11853-1/DIN 11864-1

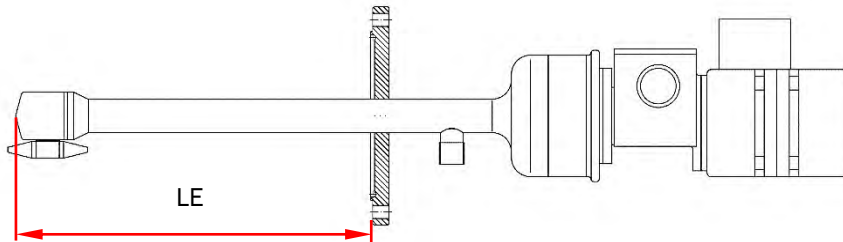

TANKO-JX70 with PC according to DIN 11853-1/DIN 11864-2

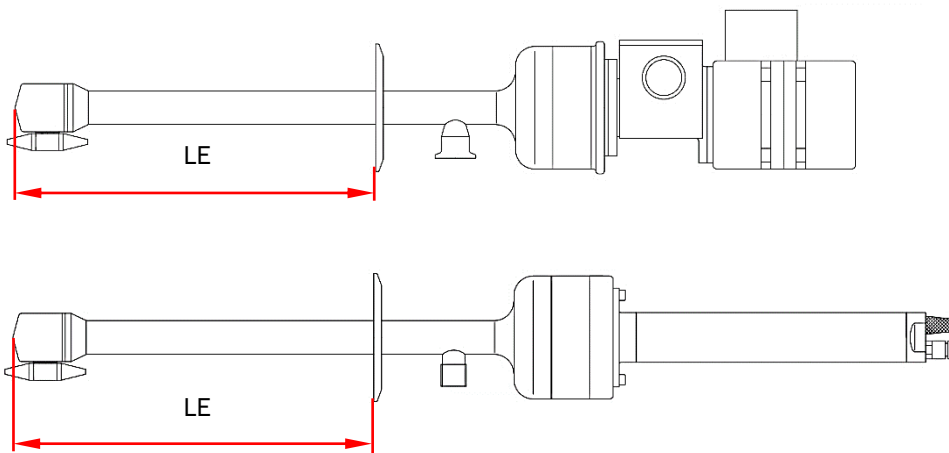

TANKO-JX70 with PC according to DIN 32676

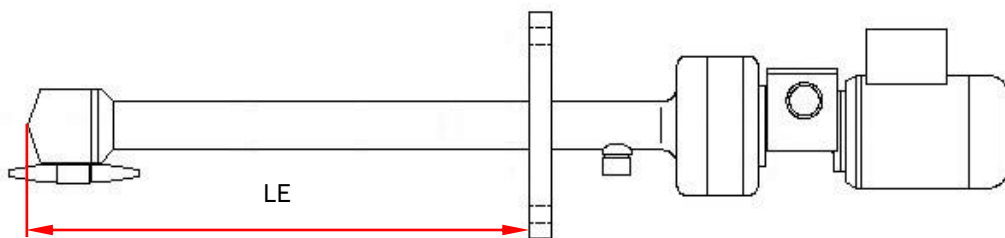

TANKO-JX75 with PC according to DIN EN 1092-1

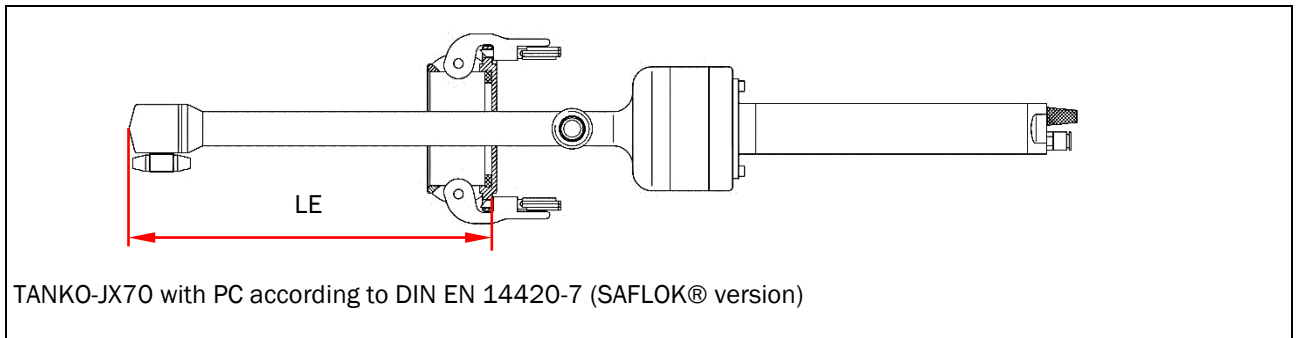

Figure 3.1-4: Device with PC Version B1 (Examples)

Version B2 - Device with Sliding Process Connection [PC]

NOTE

Risk of damage to the device and/or its surroundings!

For a device with a sliding process connection that is attached to the container, there is a risk of collision due to displacement of the device when the force-fit connection of the process connection is loosened.

This can result in material damage.

- Ensure that there are no interfering contours in the immediate installation space of the end positions and in the area in which the device can be moved.
- Additionally secure process connection [PC] against displacement (e.g. with a clamp).

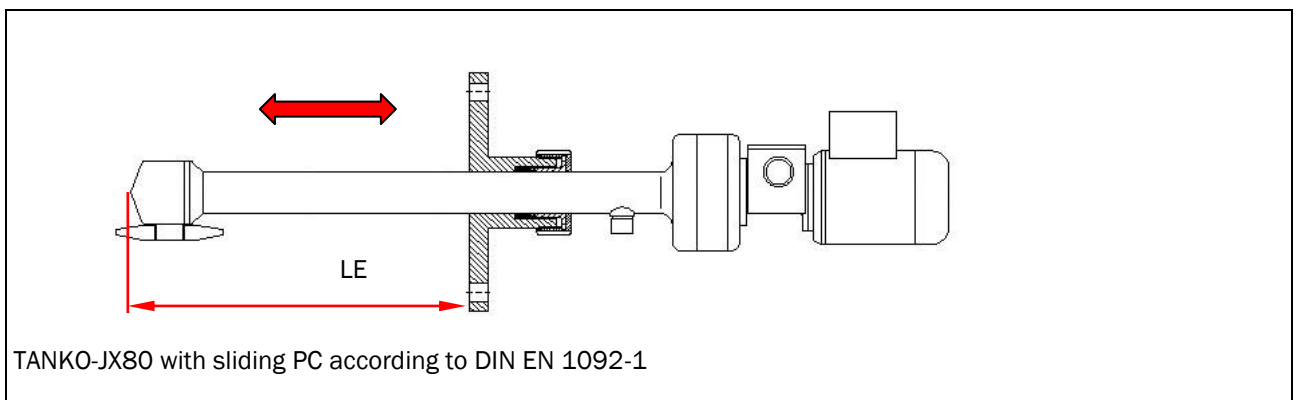

Figure 3.1-5: Device with PC Version B2 (Example)

Devices in this version consist of a basic device without process connection and a mechanically sliding process connection [PC]. With this connection, it is possible to manually set different installation lengths [LE] and to position the cleaning head differently in the container. This makes it possible to reach and clean different areas and larger surfaces in the container more easily. Due to the adjustable installation length [LE], a device can also be attached to containers of different sizes.

Device with DPE (Optional)

For the jet cleaners TANKO-X75, TANKO-JX80 as well as TANKO-JX80/70, a downpipe extension [DPE] enables the use of the devices to be adapted to different operating conditions.

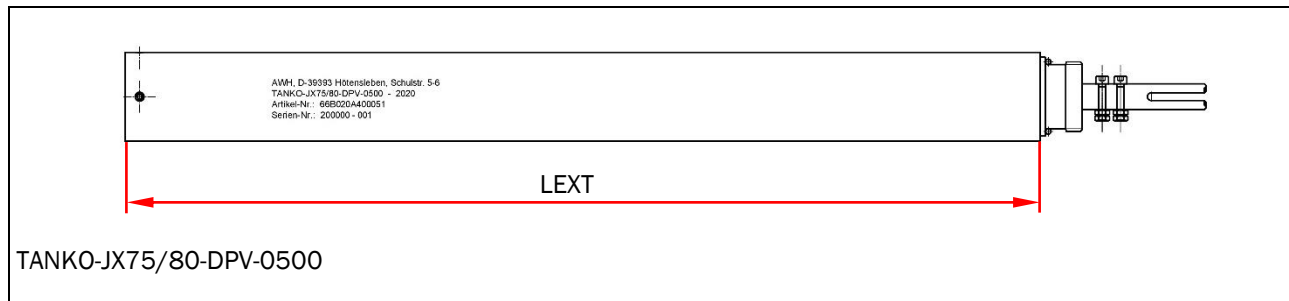

Figure 3.1-6: Downpipe Extension [DPE] (Example)

One option is to subsequently extend the installation length [LE] of an existing device. For this purpose, the cleaning head must be removed from the device and attached to the downpipe extension [DPE]. Then the DPE (with cleaning head) is attached to the device.

The total installation length should not exceed 2.5 m (=LE+LEXT). It is recommended to extend a device only with max. one downpipe extension [DPE].

Another option for optimizing cleaning is offered by the different dimensions [LEXT] of the downpipe extension [DPE]. By replacing the extension, different positions of the cleaning head in the container can be selected.

The use of a downpipe extension [DPE] can also be useful where space conditions on site are very tight in the immediate vicinity of the container installation opening (e.g. distance between vessel connector and ceiling) in order to guide the downpipe [DP] and cleaning head through the installation opening with the required installation length [LE]. The installation length [LE] for a device can be selected shortened and balanced with the length [LEXT] of a DPE, thus facilitating the installation or removal of the device.

3.2 General Function Description

The jet cleaner of the TANKO-JX series is designed as a cleaning device with an external actuator. An electric gear motor or air motor serves as the actuator.

The device is equipped with a magnetic coupling hermetically separated from the cleaning medium, consisting of two magnetic carriers. It enables permanent, contactless transmission of the torque and creates the prerequisite for complete separation (zones/areas) of the actuator from the cleaning area.

The magnetic coupling also acts as overload protection. In case of an overload, the power train is automatically interrupted. The torque is transmitted from the actuator unit to the cleaning head of the device via a magnetic coupling on a shaft. This shaft is connected to the cleaning head via a yoke coupling.

A bevel gear is integrated inside the cleaning head. The gear unit comprises one fixed bevel gear wheel and one circulating bevel gear wheel. The circulating bevel gear wheel drives the nozzle carrier (with nozzles). The rotation of the circulating bevel gear wheel around the axis of the fixed bevel gear wheel and the forced rotation around its own axis generates the orbital rotary movement of the nozzles around the cleaning head.

The orbital movement of the jet creates a cleaning pattern on the inner surface of the container, the mesh size of which depends on the number of teeth on the gear wheels, the number of nozzles and the distance from the container wall.

The jet-blast principle of the nozzles concentrates the cleaning medium, generating a high-energy jet. The mechanical cleaning effect depends on the outlet speed, the mass and the angle of impact of the cleaning medium.

The intensive cleaning jets dislodge the deposits adhering to the container wall, rinse them off at high speed and discharge them.

Very good cleaning results can be achieved using the jet cleaner for soluble substances and if the appropriate jet cleaner is selected for the respective container size.

Differently sized devices, variations of head sizes, nozzle quantity and the nozzle bore are available to suit the specific requirement and the size of the container.

The container outlet must be open during a cleaning process, i.e. no accumulation of cleaning medium should occur. When the device is not in operation, the supply line must be closed off as close as possible to the media connection [MC] using a permanently sealed shut-off fitting.

Note on the Use of Devices within the Effective Range of Internal Fittings

If the jet cleaner is used within the effective range of internal fittings, i.e. if there is a possibility of collision between the device (downpipe [DP] with cleaning head) and moving internal fittings in the container, safe operation of the device is only possible with additional protection measures.

The operating company should also conduct a hazard or risk assessment to identify and implement the functional requirements for the device controller, and, if necessary, additional monitoring equipment on the container to prevent collisions between the device (downpipe [DP] with cleaning head) and any internal fittings. The following functions and associated monitoring must be ensured:

- The rest position of moving internal fittings must be defined and monitored.
- Cleaning may only be started if the device is attached securely to the container and all connections are technically leakproof.
- The process may only be restarted after a completed cleaning process if the downpipe [DP] with the cleaning head is no longer located in the effective range of the internal fitting or the device was removed from the container.

It must be ensured that the cleaning process can be started only if moving installations in the plant that could collide with the effective range of the device (downpipe [DP] with cleaning head), are in their rest position outside the effective range of the device and are secured against being turned on again. This system must guarantee a high level of safety.

Application Examples for Jet Cleaners

Tanks, silos, barrels, containers, pipes, dryers, centrifuges, agitators, vacuum tanks, spray towers, container washing plants, fermenters, filters, mixing containers and horizontal dryers.

Comment on the Cleaning Process

The result of a cleaning process with the device, like all other cleaning processes, depends on multiple parameters. According to the "Sinner's Circle", the four most important parameters for cleaning are:

- Chemicals (cleaning medium, plus the product and its concentration)
- Mechanical power (removal of dirt, establishment of contact with the cleaning medium)
- Temperature
- Time (reaction time of the cleaning medium and duration of the cleaning process)

All four factors are interdependent and variable in relation to each other in terms of their magnitudes.

The desired cleaning result can only be achieved with a well-balanced combination of pressure, flow, reaction time, temperature and cleaning medium.

3.2.1 JX Function



The item numbers shown in brackets refer to [Table 7.5-5: Parts List for Motor Connection AG JX75 and JX80 \(Standard\)](#)

If the device is connected to the container and ready for operation, the cleaning process can be started. First, the cleaning medium is released and supplied! The cleaning medium enters the unit via the media connection [MC] and flows through the downpipe AG (1) in the direction of the head AG (2). The fluid flows through the holes of the shaft (2.7) and nozzle gear WA (2.9) into the nozzle carrier (3.1). From here, the cleaning medium is distributed to the nozzles (3.5) in a flow-optimized manner by the jet concentrators (3.4) and sprayed into the container via the nozzle openings.

The leakages occurring at the cleaning head (2), e.g. in the area of the housing bushing (2.1), are partly due to the design and are simultaneously used for self-cleaning. Only when the cleaning medium is sprayed into the container via the nozzles (3.5) may the external actuator (4) of the device be switched on.

The torque is first transmitted from the external actuator (4.1) to the head AG (2) of the device via a magnetic coupling. The coupling consists of the shaft-side magnet carrier WA (1.5) and the motor-side magnet carrier WA (4.4). The motor-side magnet carrier WA (4.4) is mechanically connected to the output shaft of the actuator and the shaft-side magnet carrier WA (1.5) is mechanically connected to the shaft WA (1.2). The torque is further transmitted via the shaft WA (1.2) via the movable yoke coupling between the shaft WA (1.2) and shaft (2.7) into the head AG (2). Inside the head AG (2) there is a bevel gear consisting of a stationary shaft gear (2.8) and a rotating nozzle gear WA (2.9).

The torque applied causes the moving parts of the head AG (2) to rotate. Here, the rotating nozzle gear WA (2.9) drives the nozzle holder AG (3). The rotation of the nozzle gear WA (2.9) around the fixed shaft gear (2.8) and the forced rotation around its own axis results in the orbital rotation of the nozzles (3.5).

The different number of teeth of the bevel gear wheels causes an offset in the nozzle position with each revolution and thus the initiation of a 360° spray angle.

Cleaning is terminated by first switching off the external actuator (4.1) and then switching off the supply for the cleaning medium!

Cleaning Times:

The speed of the cleaning head depends on the output speed of the external actuator and the transmission ratio within the device. In this way, the speed of the cleaning head can be adapted to the various operating situations by means of different external actuators.

Cleaning Times JX70:

- A complete cleaning cycle is completed after 24 revolutions. At a speed of 14 rpm, 1.7 minutes are required for a complete cleaning cycle.
- In order to determine the cycle time, divide the number 24 by the number of revolutions of the output speed of the actuator per minute.

Example (cleaning time for one cycle):

24 revolutions: 14 rpm = 1.7 min x 60 s/min ≈ 103 s

Cleaning Times JX75/JX80:

- A complete cleaning cycle is completed after 31 revolutions. At a speed of 14 rpm, 2.2 minutes are required for a complete cleaning cycle.
- In order to determine the cycle time, divide the number 31 by the number of revolutions of the output speed of the actuator per minute.

Example (cleaning time for one cycle):

31 revolutions: 14 rpm = 2.2 min x 60 s/min ≈ 133 s

After installation of the device, you must check the speed of the cleaning head (see [Section 6.2 Functional Check/Trial Run](#)).

3.3 Technical Data

The estimated safe service life of the device is 10 years with single-shift operation and the use of drinking water.

The prerequisites for this are that the device must be maintained properly at the intervals specified in [Section 7.4 Maintenance](#) and the wear parts must be replaced regularly.

All media other than tap water can reduce the service life of the device.

Designation	TANKO-JX70	TANKO-JX75	TANKO-JX80
Cleaning process			
Range			
– Cleaning radius	2.1 m (6.9 ft)	5 m (16.4 ft)	6 m (19.7 ft)
– Wetting radius	4.3 m (14.1 ft)	6 m (19.7 ft)	7 m (22.9 ft)
Volume flow rate/flow:	3 – 75 l/min 0.2 – 4.5 m ³ /h	5 – 200 l/min 0.3 – 12 m ³ /h	5 – 200 l/min 0.3 – 12 m ³ /h
– 2-nozzle	≈ 3.3 – 40 l/min ≈ 0.2 – 2.4 m ³ /h	≈ 10 – 120 l/min ≈ 0.6 – 7.2 m ³ /h	≈ 10 – 120 l/min ≈ 0.6 – 7.2 m ³ /h
Operating pressure	2 – 20 bar (29 – 290 psig)		
– Cleaning medium	2 – 20 bar (29 – 290 psig)		
Pressure in the container	0 to 0.5 bar (0 to 7.25 psig)		
Operating temperature	+5 °C to +95 °C (+41 °F to +203 °F)		
– Cleaning medium	+5 °C to +95 °C (+41 °F to +203 °F)		
Ambient temperature	+5 °C to +95 °C (+41 °F to +203 °F)		
– inside the container	+5 °C to +95 °C (+41 °F to +203 °F)		

Designation	TANKO-JX70	TANKO-JX75	TANKO-JX80
Cleaning time (standard)	≈ 103 s/cycle See Section 3.2.1	≈ 133 s/cycle See Section 3.2.1	≈ 133 s/cycle See Section 3.2.1
Rest state			
Pressure in the container	(See Section 2.1 Table 2.1-1: Permissible Parameters for the Rest State)		
Ambient temperature	(See Section 2.1 Table 2.1-1: Permissible Parameters for the Rest State)		
Installation Dimensions			
Process connection [PC]	Screw pipe connection DIN 11851 - DN 80	Screw pipe connection DIN 11851 - DN100	Screw pipe connection DIN 11851 - DN125
Media connection [MC]	DIN ISO 228 - G 1/2" (BSP) outside	DIN ISO 228 - G 3/4" (BSP) outside	
Installation opening min. – Stationary device	≥ Ø 60 mm (2-nozzle) ≥ Ø 75 mm (3-nozzle) ≥ Ø 70 mm (4-nozzle)	≥ Ø 100 mm (2-nozzle) ≥ Ø 125 mm (3-nozzle) ≥ Ø 120 mm (4-nozzle)	≥ Ø 115 mm (2-nozzle) ≥ Ø 155 mm (3-nozzle) ≥ Ø 145 mm (4-nozzle)
– Mobile device	≥ Ø 85 mm	≥ Ø 145 mm	≥ Ø 190 mm
No. of nozzles – optional	2 1; 3 or 4	2 1; 3 or 4	
Nozzle bore	Ø 1 - 4 mm	Ø 2 - 6 mm	Ø 2 - 8 mm
Nozzle movement (orbital)	Ball Ø 100 mm (3.93 in)	Ball Ø 190 mm (7.48 in)	Ball Ø 240 mm (9.44 in)
Jet movement	360° orbital		
Installation length [LE] – LE standard	300/500/750/ 1000 mm	485/735/985 mm	500/750/1000 mm
– LE adjustable	---	on request (optional)	on request (optional)
Downpipe extension [DPE] – Length [LEXT]	–	500/750/1000 mm	
Actuator			
Actuator type – Electrical – Pneumatic	Actuators see Annex 2: Overview of Actuators Electric gear motor Air gear motor		
Translation – Actuator: Cleaning head	1: 1		
Cleaning head speed – Permissible – Recommended – Standard	5 - 60 rpm 10 - 20 rpm ≈ 14 rpm		
Emission noise pressure level – Outside the container	Depending on the condition of the container! The noise pressure level can exceed the maximum permissible exposition value of $L_{EX, 8h} = 85$ dB(A).		
– Electric motor – Air motor	Device in idle mode/operation without cleaning medium $L_{pA \text{ max.}} \leq 70$ dB(A) $L_{pA \text{ max.}} = 79$ dB(A) with silencer		
Miscellaneous			
Materials (without actuator) – in contact with media – other	1.4571 (AISI 316Ti), PTFE; PEEK; iglidur X 1.4301 (AISI 304); 1.4401 (AISI 316); 1.4404 (AISI 316L); 1.4408 (AISI 316L); 1.4435 (AISI 316L); 1.4568 (AISI 301), EPDM; FKM (VITON®); FKM+FEP-coated		

Table 3.3-1: Operating Parameters of the Device (Standard)



Media [MC] and process connection [PC]

These connections can be implemented via an adapter or, in the case of special devices, directly in other versions (e.g. flange, tri-clamp, etc.). The instructions in [Section 3.1.1 Special Designs](#) and [Section 5.2.3 Installing the Device](#) must be observed.



Installation opening

The specified dimensions of the installation opening are recommended minimum dimensions for installing the device with the cleaning head in the container in an assembled state. The required size of the opening varies depending on the number and size of the nozzles and depends on the type of use as a "stationary or mobile device". Smaller installation openings using the device are possible (e.g. by using shorter nozzles). The instructions in [Section 3.1.1 Special Designs](#) and [Section 5.2.3 Installing the Device](#) must be observed.

Description	TANKO-JX70	TANKO-JX75	TANKO-JX80
Installation length [LE]	300 mm	1000 (985) mm	1000 mm
Weight* Electric actuator: SEW type SF 37	approx. 35 kg (77.2 lb)	approx. 44 kg (97 lb)	approx. 45 kg (99.2 lb)
Weight* Pneumatic actuator: Atlas Copco Type LZB 34 RL LR10-11 Type LZB 34 RL LR44-11	approx. 12 kg (26.5 lb) approx. 12 kg (26.5 lb)	approx. 21 kg (46.3 lb) approx. 21 kg (46.3 lb)	approx. 22 kg (48.5 lb) approx. 22 kg (48.5 lb)

Table 3.3-2: Weight Comparison (Examples)

* The dimension and weight data given are approximate values.

3.4 Cleaning Media

Due to the wide variety of practical cases of application and use for the cleaning device, it is NOT possible for AWH to recommend specific cleaning media for the operating company.

The operating company bears the sole responsibility for the type of cleaning media, their use and handling.

For this reason, AWH can provide the operating company with **a few reference points and notes** (for a device in a container) **but only as a precautionary measure**, which must be observed and integrated into the operating company's hazard and risk assessments.



DANGER



Risk of explosion as a result of the formation of a potentially explosive atmosphere!

Splashing or spraying of incorrect fluids to clean the container can create a potentially explosive atmosphere.

There is a risk of death or severe physical injury.

- *The following items are **PROHIBITED** for use as cleaning media:*
- *Fluids which may form a dangerous potentially explosive atmosphere or an explosive mixture when splashed or sprayed.*
- *Fluids which cause a chemical reaction with the substance to be cleaned that could form a dangerous potentially explosive atmosphere or an explosive mixture.*
- *Corrosive, flammable or explosive fluids (e.g. acids, thinners, etc.).*



WARNING



Danger due to corrosive and irritant cleaning medium!

When handling the cleaning medium, it is IMPOSSIBLE TO EXCLUDE the risk of inhalation, swallowing, contact with the skin, eyes and mucous membranes.

There is a risk of death or severe physical injury.

- *Adhere to the regulations and specifications in the safety data sheets for the cleaning media (e.g. vapors or hazardous substances).*

**CAUTION*****Danger as a result of using incorrect cleaning media!***

Due to their material resistance, the materials used in the device impose certain limitations on the cleaning media used.

Failure to observe these restrictions can result in the failure of components or a device malfunction, causing material damage and consequential damages.

- *The cleaning media must be approved for all of the materials of the device (e.g. gaskets, bushings) and for the substances to be cleaned in the container that come into contact with it.*
- *Cleaning media containing the following (corrosive) substances may NOT be used:*
 - *chlorine and chlorine ions*
 - *substances containing salt (no resistance to seawater)*
 - *medium-concentrated to highly concentrated organic acids*
 - *strong acids, in particular nitric acid and sulfuric acid (with acid content >65%)*
 - *aliphatic, aromatic and chlorinated hydrocarbons*
 - *phenols*
 - *fluorine compounds*
- *Cleaning media containing solids or liquids with solid particles or solid content (e.g. abrasives) which can lead to increased wear and/or blockages of the spray holes may NOT be used.*

NOTE***Risk of damage to the device from the cleaning medium!***

Dirt or foreign objects in the cleaning medium can have a negative effect on the function of the device.

There is a risk of material damage and consequential damages.

- *Use a suitable filter system in the cleaning medium supply line. The use of a filter with a filtration effect corresponding to a mesh width of 50 µm is recommended.*
- *Adhere to the instructions on supply and return lines in [Section 5.2 Installation](#).*

The Following Media are Permitted for Use for Container Cleaning:

Only clean, sprayable fluids may be used.

The process of spraying and jet cleaning with fluids always requires individual consideration by the operating company.

- Water
- Water-based solutions (e.g. water with alkaline cleaning additives and similar).



For proper use in food or pharmaceutical applications, the cleaning media must meet the hygienic requirements for this or be suitable or approved. If possible, only environmentally compatible media should be used for cleaning.

NOTE Applications with fully demineralized water:

Ultra pure water, ultra pure water vapor and ultra pure water vapor condensate can have extremely corrosive effects under certain conditions. Particularly with elevated operating temperatures (e.g. 80 °C to 120 °C) and with increasing operating time, corrosion reactions are possible including where stainless steel is used.

The appearance of corrosion on supposedly stainless steels occurs in various classes or types and depends on countless influencing parameters such as temperature, pressure, degree of mineralization of the media (pH value and electrical conductivity) and operating time.



In practice, the special types of corrosion of stainless steels cannot always be prevented, but can be significantly minimized and delayed.

If you have any questions or uncertainties about this, please consult AWH!

4 Transportation and Storage

AWH products are checked carefully before they are dispatched, and are packaged in accordance with the respective transportation and storage conditions. However, it is NOT possible to rule out the possibility of damage during transportation completely.

CAUTION



Risk from protruding sharp edges on the device!

Depending on the design, the device may have protruding sharp edges which can be dangerous when handling it.

There is a risk of minor cuts.

- *Wear protective gloves when working on the device.*
- *When handling, e.g. unpacking, transportation without packaging, assembly/disassembly and maintenance work, beware of protruding sharp edges.*

In the event of damage (including cases involving spare and wear parts) please contact AWH immediately with a damage report.

Scope of Delivery

- Container cleaning device
- Operating and installation instructions
- Technical documents in accordance with the order (e.g. instruction for actuator/motor, certificates and reports)
- Downpipe extension AG (optional, must be ordered separately if required)

The scope of delivery ends at the interfaces of the device (see [Section 5.2.1 Interfaces](#)).

NOT included in the scope of delivery:

- Fasteners required for fastening the device to the container (e.g. screws, nuts, clamps)
- Gaskets
- Equipment, such as filter, shut-off fitting or flow meter for the cleaning medium
- Electrical or pneumatic components for controlling the actuator
- Energy supply lines (e.g. cables, hoses; adapters)
- Frequency converter or air pressure controller for controlling the speed of the actuators
- Additional components for devices according to [Section 3.1.1 Special Designs](#)
 - Linear unit with actuator (e.g. servo motor) and control system
 - Installation unit for connection to the guide carriage of the linear unit
 - Connection with guide and sealing system for the container
 - Energy chains for power supply lines, etc.



Refer to the delivery note and the order confirmation for full details of the scope of delivery.

Inspection on Receipt of Goods:

- Immediately check the delivery against the delivery note and the order confirmation on receipt to make sure that it is complete.
- Check the delivery for any transport damage (visual inspection).

Claims:

- Register claims for damaged and/or incomplete deliveries with the transport company immediately.
- Keep the packaging for a possible inspection by the transport company or for return delivery.

Return Delivery:

In the event of a possible return delivery, pack the device parts so that they cannot become damaged during transportation. If possible, use the original packaging and the original packaging material. If neither is available anymore, request a packaging company with specialist personnel.

- Consult AWH if you have any questions regarding packaging and transport safety.

4.1 Packaging

The device is supplied fully assembled. The packaging is selected to suit the conditions of transportation. Required accessories, spare parts, operating or installation instructions and technical documents are packaged separately and enclosed with the delivery.

The packaging should protect the device up until the time of installation against transport damage, corrosion and other damage. Therefore, do not remove the packaging until shortly before installation.

NOTE



Danger due to improper disposal!

Packaging materials are valuable raw materials and can often be re-used or usefully processed and recycled.

Improper disposal can cause environmental damage.

- *Dispose of packaging materials in an environmentally friendly manner and recycle them.*
- *Adhere to the locally valid disposal regulations.*



4.2 Transportation

NOTE Improper transportation can cause damage to the device.

The functional safety and reliability of the device may be compromised.

- Observe the symbols and instructions on the packaging.
- Always transport the device in dry condition.
- Protect the device from impact.
- If possible, use the original packaging for transportation.
- Proceed with care when unloading the device and when transporting it on your premises.
- Do not remove the packaging until shortly before installation.
- Use only the intended attachment points (e.g. transportation straps), if present.
- Do not transport the device at a temperature below -10°C ($+14^{\circ}\text{F}$).

4.3 Storage

The packaging used for the device, the components and the replacement/wear parts is designed to be stored for 3 months.

NOTE Risk of damage to the device as a result of incorrect storage!

Incorrect storage can cause damage to the device and its components and lead to premature aging (e.g. plastic parts).

The failure of components or a device malfunction can cause material damage and consequential damages.

- Adhere to the following storage conditions:
 - Store the device in the original packaging wherever possible.
 - Store the device in a clean and dry place (e.g. closed, dust-free room).
 - Store the device in stable environmental conditions.
 - Prevent major temperature fluctuations so that condensation does not form.
 - Prevent dirt and moisture from entering into the device.
 - Protect the device from the elements (e.g. formation of condensation in the device, sunlight).
 - Protect unpacked devices or components with dustproof covers. Condensation must not be allowed to form beneath the cover.
 - Store the device without the original packaging, solely on a support suitable for the contour of the device (e.g. wooden planks or wooden saddle).

Parameters for Storage (Recommended):

- | | |
|----------------------------|--|
| – Room temperature | $+10^{\circ}\text{C}$ – $+45^{\circ}\text{C}$ ($+50^{\circ}\text{F}$ – $+113^{\circ}\text{F}$) |
| – Relative humidity | max. 60% (non-condensing) |
| – Temperature fluctuations | max. 10°C (18°F) per day |
| – Occurrence of vibrations | $v_{\text{eff}} < 0.2 \text{ mm/s}$ |

NOTE



The storage conditions stated here are recommendations and may deviate from the requirements of the actuator manufacturer in individual cases, depending on the actuator. These must also be taken into account when storing the device with actuator or storing the separate actuator (e.g. as a spare part)!

- *Compare the information on the type plate of the actuator with the associated documentation from the actuator manufacturer.*
- *Consistently observe the storage conditions of the actuator manufacturer.*

5 Installation

The control system is NOT supplied by the manufacturer and must be determined by the operating company according to operation-specific requirements. The operating company must comply with the relevant manuals and safety guidelines as well as the following instructions for the control system and connection conditions:

- The currently valid version of standard EN 60204-1 Safety of machinery - Electrical equipment of machines - Part 1 (particularly Section 5) must be observed.
- The control and regulation of the plant must be carried out using hardware or safety software.
- The failure of safety devices must be detected quickly enough by suitable technical measures so that dangerous conditions are highly unlikely to occur.
- The plant must be transferred to a safe state in case of failure of safety devices.
- The electrical equipment must be protected against overload.
- The Performance Level (PL) of the control system must be designed in accordance with the conditions of use and meet the requirements of the currently valid version of EN ISO 13849-1 Safety of machinery - Safety-related parts of control systems.



When used as intended, the electric actuators are EMC compatible. For the machine/plant in which devices with electric actuator are installed, EMC compatibility depends on the type and careful use of the installation. Therefore, responsibility for compliance with the electromagnetic compatibility (EMC) requirements according to Directive 2014/30/EU lies with the system builder/manufacturer.

5.1 Safety Instructions for Installation



DANGER

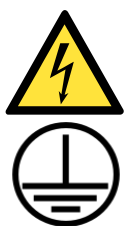

Danger to life due to dangerous contact voltage!

As the result of faulty parts, electrically conductive parts of the device that are NOT part of the operating electricity circuit, may be carrying voltage. In the event of a fault, electric shock may occur when touched.

There is a risk of death or severe physical injury.

- *The device must have an electrically conductive connection with the grounding conductor system of the plant via a PE lead so that in the event of a fault, high contact voltages are prevented via the ground potential and/or the power supply is switched off automatically (e.g. overcurrent protective devices).*
- *The grounding must always be checked before the commissioning of the device.*
- *Note the correct connection of the grounding conductor.*

WARNING



Risk of falling when working at heights!

When carrying out assembly/disassembly work on parts of the plant at heights, there is a risk of falling.



There is a risk of death or severe physical injury.



- Do not perform any work at heights except with a safety platform with cage or suitable fall protection (e.g. safety rope and safety harness).
- If you are using a harness as fall protection, it is imperative that the rescue concept for a person in the harness is observed.



- A person must not remain suspended in the harness for longer than 15 min as there is otherwise a risk of shock or even death.
- Wear protective work clothing, safety shoes, protective gloves and a hard hat for work at heights.

WARNING



Risk of accidents due to incorrect installation!

Incorrect installation, falling components or failure to comply with the indicated safety instructions can result in accidents or material damage.



This could result in death, serious injuries and/or burns.



- Only allow experts to perform work on the device.
- Only allow work on the electrical system to be carried out by **qualified electricians**.
- Before starting work, observe the **work steps of the switch-off procedure** (see [Section 7.2 Switch-off Procedure](#)).
- Wear protective work clothing, protective gloves and safety shoes for work.
- Do not work on the device unless it is disconnected from the power supply, depressurized and in a cool state.
- Maintain a safe distance when working on the device. We recommend that you provide 1 m of space for free movement around the device and container.
- Use only approved lifting gear and attach the device to the lifting gear with approved lifting devices (e.g. by wrapping a rope belt around it).

CAUTION



Risk from protruding sharp edges on the device!

Depending on the design, the device may have protruding sharp edges which can be dangerous when handling it.

There is a risk of minor cuts.

- Wear protective gloves when working on the device.
- When handling, e.g. unpacking, transportation without packaging, assembly/disassembly and maintenance work, beware of protruding sharp edges.

**CAUTION*****Insufficient lighting in the work environment!***

The device is NOT equipped with any lighting. Insufficient lighting when working on the device can cause accidents.

There is a risk of minor or moderate injuries.

- *Make sure that there is sufficient and even lighting in all areas of the plant in which the device is used when work is performed on the device.*
- *In Germany, the technical rules for workplaces apply - ASR A3.4. Illuminance of **300 lx (lux)** is recommended (maintenance value).*

Connection to the Power Supply

Connection to the power supply should only be established once the device is securely attached mechanically to the container. The connections must be established in such a way that a permanent, secure connection is maintained.

- Hydraulic connections must fulfill the requirements of EN ISO 4413.
- Pneumatic connections must fulfill the requirements of EN ISO 4414.
- Electrical connections must fulfill the requirements of EN 60204-1.

Operation of the device without cleaning medium is not permitted and is only permitted for a limited time for certain situations without cleaning medium (see [Table 6.4-1: Time-limited Operation of the Device without Cleaning Medium](#)). Therefore, it is necessary to continuously monitor the supply of the cleaning medium during cleaning. A malfunction must be detected, registered and evaluated at an early stage in order to immediately transfer the device to a safe operating state.

A disruption to the supply of the cleaning medium can be caused by the following, for example:

- Pump failure (e.g. pump defective, power failure, cable break or loose contact, etc.).
- Deterioration of the filter performance of the installed filter (e.g. filter clogged).
- Shut-off fitting closed.
- Leaks (leakage) at sealing points of the connections and/or line connections.

For detection and monitoring of the fluid flow, a flow meter/monitor is recommended by the manufacturer as the measuring device.

A flow meter consists of two main components, the measuring sensor, which serves as the flow sensor, and an evaluation and supply part, the transmitter.

When selecting the measuring device, attention must be paid to the measuring ranges for pressure and temperature, the fluid to be measured, the type of connection, the nominal width, and the degree of protection, depending on the process and environmental conditions.

The flow meter should be installed in the immediate vicinity of the media connection [MC] upstream of the device. The manufacturer's instructions for the measuring device for installation must be observed.

**WARNING*****Danger due to swinging hydraulic equipment!***

In certain operating states, screw and clamp connections may unforeseeably loosen due to significant swinging motions and/or vibrations. This means it is possible for leaks to form at the sealed points of the connections and line connections, from which hot and/or corrosive fluid may spray out at high pressure.

There is a risk of death or severe physical injury.

- *All connections and line connections should be securely attached without mechanical tension and permanently technically leakproof.*
- *During initial commissioning, the swinging and vibrations of the device must always be observed and, insofar as is possible, tested under various operating conditions.*
- *In the event of swinging and/or vibrations, avoid releasing the connections by additional measures, such as spot welding or bonding (e.g. Loctite).*

**WARNING*****Danger due to improper connection to the power supply!***

The technical data, the connected loads for the power supply (electric or pneumatic) depend on the type of actuator mounted.

Failure to observe the instructions for the actuator can result in various sources of danger.

There is a risk of death or severe physical injury.

- *Observe the type plate of the actuator.*
- *Compare the information on the type plate of the actuator with the associated documentation from the actuator manufacturer.*
- *Consistently observe the connection conditions of the actuator manufacturer.*

Connection to Disposal System

NOTE



Danger due to improper disposal!

The medium used for cleaning may contain chemical additives and may additionally become contaminated with residues (e.g. sludge particles) from the previous production process during cleaning. Waste may contain various harmful substances and may NOT be disposed of in ground water, in water courses or in the sewage system.

Improper disposal can cause environmental damage.

- Please note the safety data sheets for the cleaning media:
 - Comply with the hazard and disposal instructions.
 - Set out protective measures and compile operating instructions for hazardous substances.
- Following cleaning, dispose of the contaminated cleaning medium in an environmentally-friendly manner in accordance with the locally applicable regulations, or ecologically recycle it.

The cleaning media used for the cleaning process may NOT present a danger to the safety and the health of persons even after cleaning. Risk due to filling, use, recovery and disposal is to be avoided.

Depending on the application and properties of the system/container, appropriate measures should be taken to ensure after cleaning that the used/draining medium is properly fed to a preparation or disposal system.

5.2 Installation

The safety instructions in [Section 5.1 Safety Instructions for Installation](#) must be adhered to before installation of the device in the container.

CAUTION

Fault due to incorrect installation position/location of the device!

Any installation of the device NOT performed correctly can cause damage to the device which puts the functional safety and reliability at risk during commissioning.

That can result in hazards.

There is a risk of minor or moderate injuries.

- When selecting the installation position of the device, make sure that
 - a safe distance is maintained from the internal wall of the container and from nearby components, in order to prevent scraping or impact during operation and
 - It is imperative to prevent collisions while the cleaning head and surrounding components (e.g. agitators) are moving simultaneously.
- Install the device free of mechanical tension.
- Refer to the installation dimensions in [Table 3.3-1: Operating Parameters of the Device \(Standard\)](#) or the device drawing.

**CAUTION*****Fault as a result of dirt, foreign objects or damage to the device!***

Foreign objects such as scale, burrs, chips, etc. can restrict flow or get into the piping system and cause malfunctions or damage to components, including gaskets. This can result in hazards that endanger the functional safety of the device.

There is a risk of minor or moderate injuries.

Before the device is installed for the first time and for assembly after conversion work on the system in which the device is installed, the following measures must be taken.

- *All supply and return lines for the cleaning medium must be rinsed with clear water in order to remove any contamination, foreign objects or residue in the supply line (e.g. scale, chippings, welding particles etc.).*
- *Take suitable measures to prevent dirt and foreign objects from entering via the interfaces of the device. Install a filter upstream of the media connection [MC] in the supply line for the cleaning medium (see [Section 3.4 Cleaning Media](#)).*
- *Paint must not be applied to the surface of the device.*

Please also note:

- If the device is used outdoors or in rooms where there is a risk of frost, it must be protected against freezing.
- The devices must not be equipped with thermal isolation.
- After installation, it must be ensured that all parts of the device have a conductive connection with the container and are grounded (leak resistance to ground $R_E < 10^6 \Omega$ [ohm])

5.2.1 Interfaces

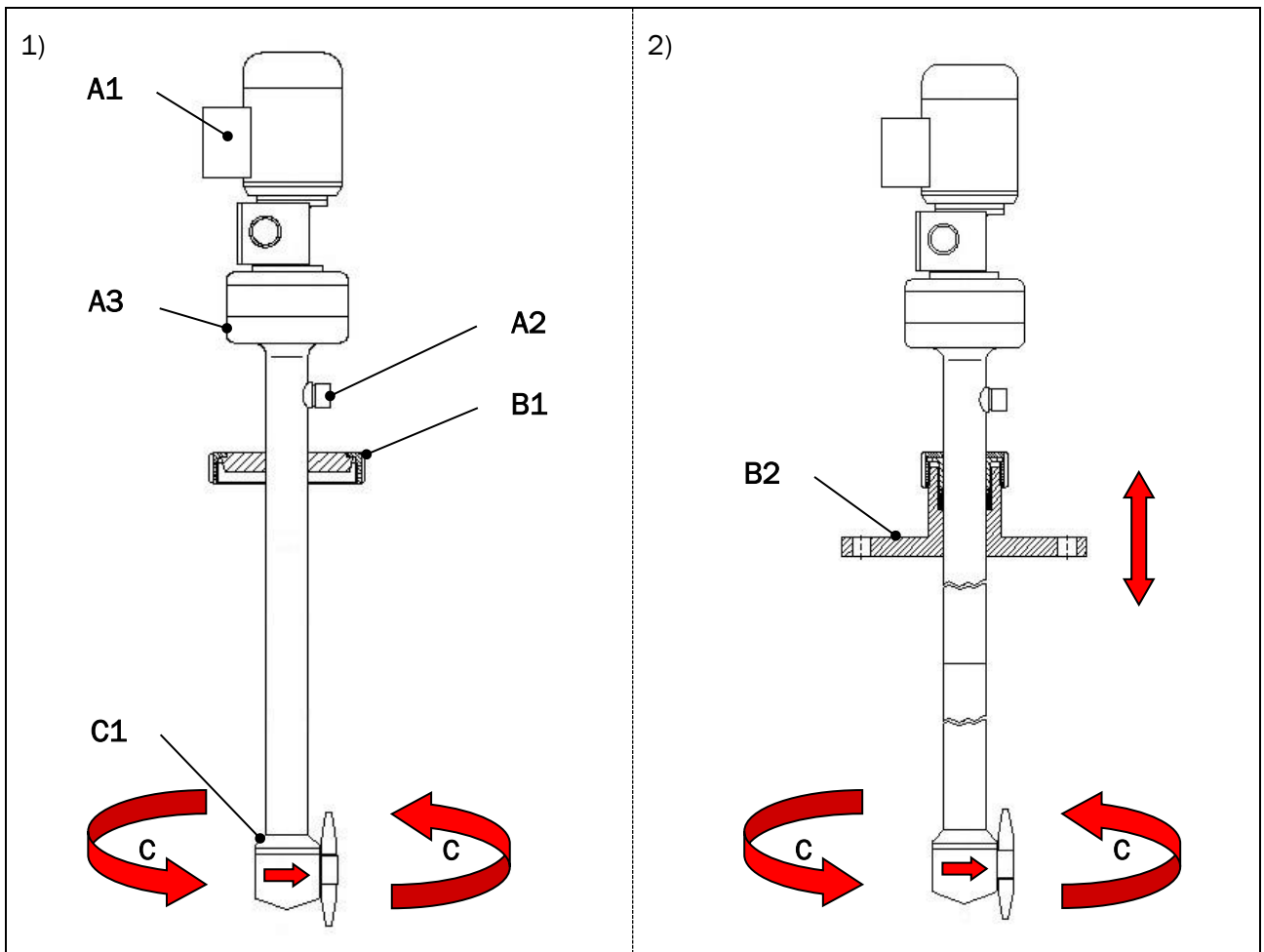

Figure 5.2-1: Device Interfaces

A Actuator/Energy Supply:

- A1 – Electrical or pneumatic connection for the actuator (e.g. terminal box)
- A2 – Media connection [MC]
- A3 – Rinsing connection [RC] - optional

B Device/Container:

- B0 – Device without process connection [PC] (special design not shown in Fig.)
- B1 – Process connection [PC], permanently welded (standard design)
- B2 – Process connection [PC], sliding (special design)

C Room for Movement/Installation Space:

- C1 – Cleaning head with nozzles (space for orbital nozzle movement and outlet of cleaning medium)

5.2.2 Installation Position

Vertical Installation Position - Cleaning Head Pointing Downwards (Standard)

In this installation position, the device achieves its optimum operating levels and self-drainage of the device is ensured. Installation positions within the specified angles are permissible.

Different Installation Position from the Standard

In the event of an installation position that differs from the standard, observe the following:

- The running performance may be compromised.
- The service life of the bearing elements may be shortened as a result of the increased strain.
- Maintenance intervals should be shortened (see [Section 7.4.1 Maintenance Intervals](#)).
- Self-drainage of the device is NOT always guaranteed.
- Check the spatial position of the actuator (see [Annex 2: Overview of Actuators](#)).

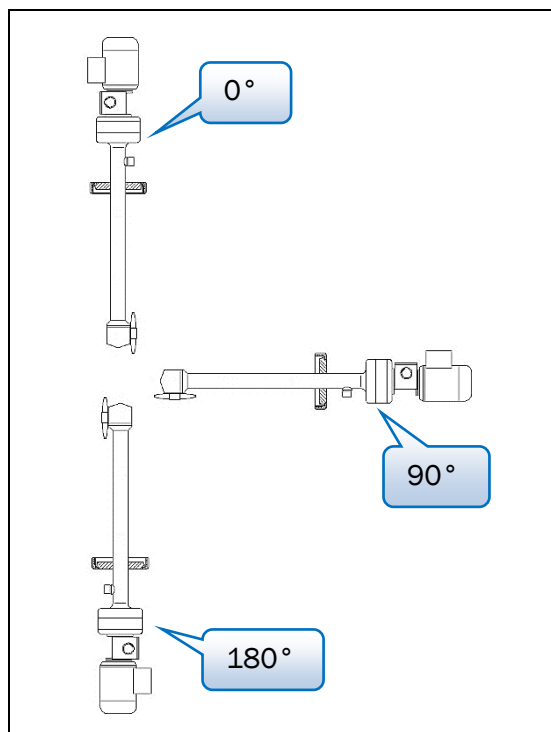

Installation position (vertical) = 0°

Cleaning head down (standard)

Installation position (horizontal) = 90°

Cleaning head horizontal

NOTE Depending on the version, increased stress on one side of the gasket must be expected at the process connection [PC] in this installation position.

This can result in leaks.

- Define shortened intervals for process connection [PC] at maintenance point "E".

Installation position (vertical) = 180°

Cleaning head up

Remark: Installation positions within the specified angles are permissible.

Figure 5.2-2: Installation Positions of the Device

In unfavorable installation positions, a separate rinsing connection [RC] (see [Section 3.1 Construction](#)) can be useful for better self-drainage, especially in the area of the magnetic coupling.

⚠ CAUTION Fault due to simultaneous operation of several devices!

If several devices are used simultaneously to clean a container, then the devices can negatively influence each other during cleaning.

Various faults (e.g. poor cleaning results) or impermissible operating states can occur.

- Maintain a minimum distance between the devices depending on their maximum cleaning power. This also applies to simultaneous operation with other devices.

5.2.3 Installing the Device

Installation Opening of the Container

The intended use of the device (mobile or stationary) is the decisive factor for the required size of the installation opening. The specified installation dimensions in [Table 3.3-1: Operating Parameters of the Device \(Standard\)](#) are recommended minimum dimensions for the installation opening and for installing the device in the container and removing it from the container in assembled condition.



We recommend using two people for assembly/disassembly.

⚠ WARNING Connections that are NOT screwed, such as separable connections with a clamp or grid design can be unexpectedly loosened or mistakenly removed!

Fluids may penetrate or spray out and be carried over between zones.

There is a risk of severe physical injury.

- Fluid and process connections in clamped or detent configuration must:
 - be self-locking (e.g. mechanical locking of a lever arm coupling with safety lock),
 - be provided with an additional securing mechanism to prevent them from coming loose accidentally or
 - a tool or key is required for loosening (e.g. replacing a winged nut with a hexagonal nut).



For clamp connections (e.g. according to DIN 11853-3, DIN 11864-3 or DIN 32676), depending on the strength and nominal width, double-joint clamps or clamps consisting of 2 individual shells are recommended. To ensure that the clamp does NOT have to be operated directly by hand, but exclusively with a tool (e.g. open-end wrench), the clamps must be designed with a locking screw and hexagonal nut.

⚠ WARNING Risk of the device falling accidentally!

The device may strike personnel when falling.

There is a risk of severe physical injury.

- Hold the device firmly when installing/removing it.
- There must be nobody beneath the device when installing/removing it.

NOTE Risk of dirt and foreign objects in the device!

Functional safety and reliability may be compromised.

- During installation, make sure and check that there is no dirt or foreign objects in the device (e.g. small particles, sealing material).

Interface A

- A1** The connections for the electrical or pneumatic actuators are to be set up in accordance with the specifications contained in the documentation from the respective manufacturer supplied.

The instructions contained in [Section 5.3 Connection of the Actuator](#) must be observed!

- A2** The supply line connection must be configured to be compatible with the media connection [MC] of the device. The supply line for the cleaning medium must be fastened permanently and in a technically leakproof manner to the media connection [MC].

- A3** If a rinsing connection [RC] is available, it must always be closed firmly and in a technically leakproof manner using the original sealing plug supplied, unless the connection is used for special applications (e.g. rinsing process).

The drainage pipe connection must be configured to be compatible with the rinsing connection [RC] of the device.

⚠ CAUTION Wrong flow direction of the cleaning medium!

The flow direction is fixed for using the rinsing connection [RC].

Failure to observe this may result in damage to the device or its surroundings.

- Remove the blanking plug and attach the drainage pipe firmly and in a technically leakproof manner to the rinsing connection [RC].
- The flow direction from the media connection [MC] to the rinsing connection [RC] must be complied with.

Interface B

The connection to the container must be designed so that it is compatible with the process connection [PC] for the downpipe [DP]. The process connection [PC] has to be fastened permanently and in a technically leakproof manner to the connection on the container (e.g. screwed or clamped) and secured to prevent it from coming loose.

For more information on the connections, see [Section 3.1.1 Special Designs](#).

- B0** without process connection [PC] (special design)
- B1** Process connection [PC] permanently welded (standard design)
- B2** Process connection [PC] movable (special design)



Fastening materials and gaskets are NOT included in the scope of delivery.

Interface C

NOTE An excessively strong cleaning jet can subject the container, the surrounding components in the container or the device itself to strong forces and cause damage!

This can result in material damage.

- Maintain sufficient distance from surrounding components during operation so the force of the cleaning jet:

- does not cause vibrations in the surrounding components,
- does NOT influence the rotary movement of the cleaning head due to recoil and
- does not provoke vibrations in the device itself (see [Section 7.4.1 Maintenance Intervals](#)).

The same applies when installing more than one device in one container!

NOTE Excessively small installation opening for the container or components (e.g. agitators) in the container!

Nozzles collide during installation.

The nozzle carrier may come loose or damage to the device may result.

- The nozzles must NOT collide!
 1. Check the following before inserting the device into the container:
 - The minimum dimension for the installation opening (see [Section 3.3 Technical Data](#)),
 - Presence of interfering contours on surrounding components in the container and
 - The nozzle carrier with nozzles is firmly in place on the cleaning head.
 2. Lift the device (downpipe [DP] with cleaning head) out of the container through the installation opening with the utmost care.

Installing the Stationary Device

A "stationary device" can be installed in different ways depending on the properties of the container and the size and accessibility of the installation opening:

- The cleaning head, together with the downpipe [DP] of the device, is inserted into the container from the outside through the installation opening.
- The cleaning head is detached from the downpipe [DP] of the device and the downpipe [DP] of the device is inserted into the container from the outside through the installation opening without the cleaning head. After that, from inside the container, the cleaning head is reattached to the downpipe [DP] of the device.

NOTE The following must be noted regarding the installation opening.

- If necessary, align the nozzles by:
 - Powerfully rotating the "bottom of the housing (2.11)" on the cleaning head in the direction of the arrow, or
 - Briefly starting up the actuator.



Figure 5.2-3: Nozzle Position Stationary Device

- Alternatively, remove the cleaning head from the downpipe [DP] and reattach it after installing the device inside the container (see [Section 7.4.3.2 Disassembly – Head AG](#)).
 - Provided that proper installation and assembly/removal of the cleaning head/device inside the container is assured and
 - the diameter of the installation opening on the container is at least 5 mm greater than the outer diameter of the downpipe [DP].

Installing the Mobile Device

⚠ CAUTION If the device (downpipe [DP] with cleaning head) is used within the effective range of internal fittings, there is a possibility of collision with moving internal fittings (e.g. agitators) in the container! Various faults or impermissible operating states can occur.

Material damage and consequential damages may occur.

- Before the device (downpipe [DP] with cleaning head) is inserted into the container through the installation opening, fix the resting positions of movable internal fittings, monitor them, and secure them against restarting.

NOTE The following must be noted regarding the installation opening.

- Smaller installation openings on the container for mobile use of the device as in [Section 3.3 Technical Data](#) are only permitted:
 - If the cleaning head fits through the installation opening with the nozzles in any position during installation and removal of the device (e.g. by using shorter nozzles) and
 - If a safety clearance of at least 5 mm is ensured between the device and the installation opening.

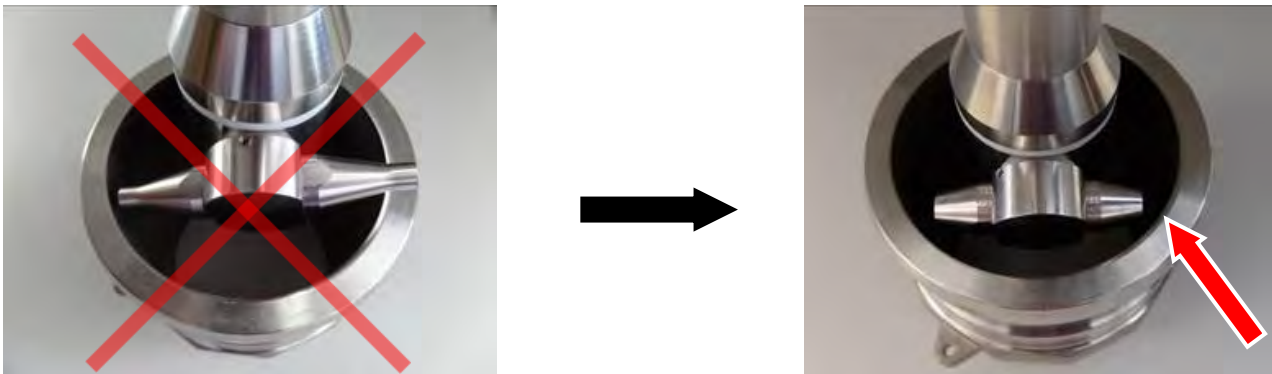

Figure 5.2-4: Installation Opening of Mobile Device

5.3 Connection of the Actuator

When the device is safely attached mechanically to the container, the connection to the power supply can be established. The connections must be established in such a way that a permanent, secure connection is maintained. The information for this can be found in the installation instructions of the actuator manufacturer.

Examples of actuators that can be used for the device are listed in [Annex 2: Overview of Actuators](#).

Electrical Connection

⚠ WARNING Danger due to improper connection to the power supply!

Various sources of danger can arise if the procedure is not carried out correctly. The connections and lines of the electric motor (e.g. terminal box) may be carrying electrical voltage. This may result in an electric shock.

There is a risk of death or severe physical injury.

- Observe the type plate of the actuator.
- Compare the information on the type plate of the actuator with the associated documentation from the actuator manufacturer.
- Consistently observe the connection conditions of the actuator manufacturer.



The installation height when installing the device is limited to max. 1000 m above sea level for electric actuators with electric motor.

Pneumatic Connection

⚠ WARNING Danger due to improper connection to the power supply!

Various sources of danger can arise if the procedure is not carried out correctly. The connections and lines of the air motor (e.g. plug-in couplings) may be under pressure! A mechanical shock may occur due to whipping of a compressed air hose.

There is a risk of severe physical injury.

- Observe the type plate of the actuator.
- Compare the information on the type plate of the actuator with the associated documentation from the actuator manufacturer.
- Consistently observe the connection conditions of the actuator manufacturer.



The required compressed air quality (e.g. filtered/dry compressed air) of the air motor can be found in the documentation of the actuator manufacturer.



Air motors tend to be relatively noisy. However, this can be reduced by taking appropriate measures, e.g. by choosing the right silencer or by routing the exhaust air away.

5.3.1 Direction of Rotation of Cleaning Head

⚠ CAUTION Wrong direction of rotation of the cleaning head!

Incorrect connection of the actuator can cause the cleaning head of the device to rotate in the wrong direction. This can cause parts of the device to come loose during operation.

Material damage and consequential damages may occur.

- Observe the connection parameters for the actuator of the device (see type plate, operating instructions and technical documents for the actuator).
- Ensure the correct direction of rotation of the cleaning head (see direction of rotation arrow).
- If the direction of rotation of the cleaning head is incorrect, change the direction of rotation of the actuator (e.g. reverse the polarity of the electric motor).



The prescribed direction of rotation of the cleaning head as seen from the motor in the direction of the cleaning head is "left". (Left = turning counterclockwise).

A "direction of rotation arrow" is located on the cleaning head of the device (see [Section 3.1 Construction](#)).

5.3.2 Speed Control

Due to the diversity of practical applications and operating conditions of the cleaning device, it is NOT possible for AWH to provide specific information for the many speed control options or special requirements in individual cases.

It is for this reason that AWH can offer the operating company, **solely as a precautionary measure, a few points of reference and notes** to be observed and to be integrated into the operating company's hazard and risk assessments.

If the cleaning process is to be optimized by adapting the cleaning cycles, this can be done by controlling the speed in certain areas, depending on the design of the actuator. The permissible speed range for the cleaning head of the device must NOT be exceeded or fallen short of (see [Section 3.3 Technical Data](#)).

The speeds of the electric gear motors can be continuously controlled using frequency converters and the air motors using air pressure controllers.

Electrical Connection (Operation with Frequency Converter)

In principle, before installation and commissioning, the permissible operation for the motor on the frequency converter and for the gear unit on the frequency-controlled motor must be checked using the corresponding documentation.

⚠ WARNING Operation using a frequency converter for the electric motor NOT permitted!
NOT every electric motor is suitable for operation with a frequency converter. If used incorrectly, unforeseen situations may develop during commissioning or during operation.

There is a risk of death or severe physical injury.

- If an electric motor is to be connected to a frequency converter, its suitability for safe operation must be checked.
- Only operate the electric motor using the frequency converter if the requirements of the motor manufacturer's documentation and the information on the motor type plate are met. The converter must meet all conditions for safe operation of the motor.
- During installation, comply with the requirements of the current EMC directive.

NOTE When operating with a frequency converter, it is possible that the permissible motor temperatures and bearing loads will be exceeded.

Damage to the electric motor and the gear unit may result.

- Observe the special characteristics of the electric motor when operating with a frequency converter.
- Observe the operating instructions of the control unit manufacturer.
- The specified maximum speed or frequency must NOT be exceeded.
- Speed changes must NOT cause the permissible motor temperatures and bearing loads to be exceeded.
- Only operate the gear unit on the frequency-controlled motor up to the specified max. actuator speed and actuator torque.

A motor with additional winding protection contact and/or a forced cooling fan may be required. Place the motor and converter as close to each other as possible. Cables must be sheathed and shielded. Cables, cable ends, frequency converter and motor must be grounded. It is recommended to use all-pole sinusoidal filters.

Pneumatic Connection (Operation with Air Pressure Controller)

The air motors can operate within a certain speed range and can be adapted to different requirements. The speed can be regulated without special effort by varying the operating pressure, by changing the air volume (e.g. throttling), or by superimposed regulation of pressure and air volume. The manufacturer's specifications such as nominal and idle speed, air consumption and the characteristic power curve/theoretical characteristic curve must be observed.

Without special measures, the air motors can also be operated oil-free with approx. 15% less power. For further information, refer to the documentation for the air motor.

6 Commissioning

Before commissioning the device in Germany, the operating company of the plant must observe the German Operational Safety Ordinance (BetrSichV).

In other countries, the respective national guidelines, statutes and country-specific regulations regarding occupational safety and accident prevention must be complied with.



WARNING

Hazardous situations as a result of incorrect installation of the device!

If the device is not installed properly, unpredictable situations may arise during commissioning or operation.

There is a risk of death or severe physical injury.

- *As a basic rule, commissioning of the device (with cleaning medium) must not be performed until the following has been checked:*
 - *Correct mechanical installation of the device on/in the container*
 - *Correct hydraulic, electrical and/or pneumatic connection*
 - *Safe and reliable functioning of the device*
 - *Setup conditions*

6.1 Safety Instructions for Commissioning

Before operating the device, the operating company must ensure that local regulations are observed during commissioning.



We recommend that you document commissioning and the corresponding operating conditions in a report.



DANGER



Danger to life due to dangerous contact voltage!

As the result of faulty parts, electrically conductive parts of the device that are NOT part of the operating electricity circuit, may be carrying voltage. In the event of a fault, electric shock may occur when touched.

There is a risk of death or severe physical injury.

- *The device must have an electrically conductive connection with the grounding conductor system of the plant via a PE lead so that in the event of a fault, high contact voltages are prevented via the ground potential and/or the power supply is switched off automatically (e.g. overcurrent protective devices).*
- *The grounding must always be checked before the commissioning of the device.*
- *Note the correct connection of the grounding conductor.*

 **WARNING*****Danger as a result of static charge!***

Containers may become statically charged during cleaning operation. There is a risk of electric shock or electrical irritation in case of contact with the hand, which could cause a startled reaction.

There is a risk of death or severe physical injury.

- Only allow experts to perform work on the device.
- Make sure that any electrostatic charge is prevented. To do so, ground the device and the container using equipotential bonding.
- Grounding must always be carried out before commissioning the device.

 **WARNING*****Danger due to hot surfaces!***

The device is delivered without additional protective measures against hot surfaces and may NOT be equipped with thermal insulation.



The device may heat up significantly as a result of the cleaning medium or the heat transfer from the container. Contact with the device can cause burns to the skin.

There is a risk of burns from the cleaning medium at temperatures above +60 °C (+140 °F).

- Safeguard hot surfaces with a guard or barriers.
- Put up warning signs in the direct vicinity of the hot surfaces.
- Wear protective work clothing and protective gloves when working.

 **WARNING*****Danger resulting from negative pressure/vacuum in the container!***

A cold cleaning process in hot, closed containers can generate negative pressure, which may lead to damage to the container.

There is a risk of death or severe physical injury.

- Take precautions to allow gases or vapors to escape during operation (e.g. install devices for ventilation and exhaust or pressure equalization).

As a result of the variety of practical applications and uses for the cleaning device, AWH CANNOT specify a noise level for the device under load, i.e. installed in the container and operating with cleaning fluid.

It is for this reason that AWH can offer the operating company, **solely as a precautionary measure, a few points of reference and notes** to be observed and to be integrated into the operating company's hazard and risk assessments.

**CAUTION*****Risk of hearing damage as a result of an increased noise level!***

The device emits a noise pressure level of $L_{pA} < 70$ dB(A).

When the device is operated in a container, the noise level may exceed the maximum permitted exposure value of $L_{EX, 8h} = 85$ dB(A) and varies depending on the properties of the container in the plant and the existing operating conditions of the device.

Hearing damage could be incurred as a result.

- The plant noise level must always be measured and documented by the operating company.
- Keep the plant noise level within the legal range:
 - Perform noise reduction measures (e.g. sound insulation).
 - Delimit and mark the noise area (e.g. with mandatory sign "Wear hearing protection").
 - Use effective hearing protection (e.g. ear muffs or ear plugs).

Comply with the technical health and safety rules relating to noise and vibration protection (called TRLV Lärm in Germany). State-of-the-art technology must be used to implement the measures to provide protection from exposure to noise based on the risk assessment. In this case, noise emissions must be prevented at source, or reduced as far as possible.

**CAUTION*****Insufficient lighting in the work environment!***

The device is NOT equipped with any lighting. Insufficient lighting when working on the device can cause accidents.

There is a risk of minor or moderate injuries.

- Make sure that there is sufficient and even lighting in all areas of the plant in which the device is used when work is performed on the device.
- In Germany, the technical rules for workplaces apply - ASR A3.4. Illuminance of **300 lx (lux)** is recommended (maintenance value).

6.2 Functional Check/Trial Run

All the screw connections on the device are firmly tightened in the factory. Nevertheless, a trial run should be carried out to check that the device functions safely and reliably, and that it is leak-tight once installed.



Do not operate the device unless it is in perfect condition.

The container to be cleaned must be emptied and depressurized.

▲ WARNING Persons in the container. Persons may be struck by the jets from the cleaning head!

There is a risk of death or severe physical injury.

- Do NOT start the cleaning process while there are persons in the container.

Functional Check

1. Close all of the openings on the container (e.g. inspection openings).
2. Switch off all moving inner fittings in the container (e.g. agitators) and secure them to prevent them from being inadvertently switched back on or set in motion.
3. Check to ensure that there is a safe distance around the container and to the surrounding components.
4. **▲ CAUTION** Wrong direction of rotation of the cleaning head!

Incorrect connection of the actuator can cause the cleaning head of the device to rotate in the wrong direction. This can cause parts of the device to come loose during operation.

Material damage and consequential damages may occur.

- Observe the connection parameters for the actuator of the device.
 - Ensure the correct direction of rotation of the cleaning head (see direction of rotation arrow).
 - If the direction of rotation of the cleaning head is incorrect, change the direction of rotation of the actuator (e.g. reverse the polarity of the electric motor).
5. Switch on the device (see [Section 6.3 Switch-on Procedure](#)).
 6. Check the interfaces on the device for impermeability.
 7. **NOTE** Risk of collision with moving parts!
Observe the following steps if inner fittings in the container need to rotate during the cleaning process:
 - Start up the surrounding inner fittings (e.g. agitators) step by step.
 - Carefully check that the cleaning head and surrounding components (e.g. agitators) do NOT collide while moving simultaneously.
 8. Make sure that there are no unusual vibrations.
 9. Check the device to make sure that it is running smoothly.
 10. Check motor for atypical noises.
 11. Switch off the device (see [Section 7.2 Switch-off Procedure](#)).

6.3 Switch-on Procedure

In accordance with the type of device activation and how it is integrated (e.g. manual or automatic) on the cleaning plant, the switch-on procedure has to be integrated and the following instructions have to be observed when switching on.



WARNING

Danger from sudden, unforeseeable or unauthorized switching-on of the device!

For example, a start command can be triggered by incorrect operation of a start control device. For a safe cleaning process it is absolutely necessary to consistently follow the sequence of safety-relevant switching processes. Non-compliance prevents operational safety, thus leading to hazards.

- *When commissioning the device, the **work steps for the switch-on procedure** must be followed in the given order.*

SWITCH-ON PROCEDURE

Work steps

1. *Securely close all of the openings on the container (e.g. inspection openings).*
2. *Empty and depressurize the container.*
3. *Switch off all moving inner fittings in the container (e.g. agitators) and secure them to prevent them from being inadvertently switched back on or set in motion.*
4. *Open the outlet of the container for the cleaning medium.*
 - *Check whether the cleaning medium fed into the container can drain freely during cleaning and does NOT collect together.*
5. *Switch on the cleaning medium supply.*
 - *Open the shut-off fitting (e.g. valve or ball cock) and start the pump slowly.*
 - *Check that the supply of cleaning medium is NOT interrupted (e.g. flow meter) and the media pressure on the device is established.*
6. *Take suitable measures to secure the supply of cleaning medium to prevent it from being switched off suddenly, unexpectedly or without authorization.*
7. *Switch on the supply of electrical power or compressed air for the device actuator.*
 - *Check to make sure that the energy supply is NOT interrupted and that it is provided to the device.*
8. *Secure the supply of electric power or compressed air for driving the device against sudden, unforeseeable or unauthorized disconnection.*

NOTE***Risk of breakage due to material overload!***

Pressure surges when switching the cleaning medium on or off, in particular pressure surges which exceed the operating pressure, and gas components in the cleaning medium may cause hammering in the cleaning device.

There is a risk of material damage or destruction of plant parts, (e.g. leakage in the pipe system or on connected devices).

- *Prevent pressure surges ("water hammers") and gas components in the cleaning medium, e.g. caused by:*
 - *installing a water hammer arrester or pressure relief valve in the supply line,*
 - *starting/stopping the pump slowly and*
 - *opening/closing the shut-off fitting slowly (e.g. valve or ball cock).*

The term "water hammer" denotes a pressure surge in a fluid line which is generated by opening/closing a shut-off fitting (e.g. valve or ball cock) quickly at the end of a pipeline.

Pressure hammers/pressure surges can also be provoked by quick changes in the flow rate (pressure increase or pressure drop), or by sudden changes in the direction of the flow of fluids. This effect is particularly common in pump systems with long pipelines when starting up, stopping or changing the speed of pumps.

6.4 Operation

Once it has been commissioned and inspected, the device can be put into operation, observing the following instructions.

**WARNING*****Risk when used outdoors!***

The devices are usually operated in a closed factory hall and are thus protected from the risk of lightning. If the device is used outdoors, there is a risk of lightning in the case of a storm.

There is a risk of death or severe physical injury.

- *Protect the plant in which the device is installed with suitable lightning protection measures.*
- *In case of use outdoors and in case of storms or the risk of lightning, stop work immediately.*

WARNING

Risk if the operating/working area is accessed by unauthorized persons!

Unauthorized persons are NOT familiar with the hazards in the working area as described in these instructions.

There is a risk of death or severe physical injury.

- Permit only authorized specialist personnel who are qualified and trained for the operation to operate the cleaning device.
- Keep unauthorized persons away from the working area of the plant/machine in which the device is installed.
If in doubt, address these persons and order them to exit the working area.
- Stop the work for as long as there are unauthorized persons in the working area.

WARNING

Risk of chemical burns and heat burns when opening the container!

The supply line is pressurized. The person may be struck by cleaning jets or come into contact with residual fluid from the supply line and device. There may also be hot vapors in the container.



There is a risk of death or severe physical injury.



- **Do NOT open the container during the cleaning process.**
- Before starting work, adhere to the **work steps of the switch-off procedure** (See [Section 7.2 Switch-off Procedure](#)).
- Before opening the container, observe the **cooling and draining time**.
- Use personal protective equipment (e.g. protective gloves, safety shoes, safety goggles).



WARNING

Danger due to hot surfaces!

The device may heat up significantly as a result of the cleaning medium or the heat transfer from the container. Contact with the device can cause burns to the skin.



There is a risk of burns from the cleaning medium at temperatures above +60 °C (+140 °F).

- Comply with the warning signs and do NOT touch the marked areas.
- Do NOT remove insulation from protected hot surfaces.
- Maintain a safety distance from existing protective equipment or barriers.
- Use protective equipment (e.g. protective gloves; cloths) to provide protection from the hot surface.
- Do not touch the device until after a sufficient cooling time.



WARNING

Danger caused by ejection of the cleaning medium!

If the cleaning medium is unexpectedly ejected after a system failure (e.g. pressure drop due to interruption of the pressure supply) there is a risk of accident.

There is a risk of death or severe physical injury.

- Do NOT remove the device if the cleaning medium has failed.
- Always follow the work steps of the **switch-off procedure** (see [Section 7.2 Switch-off Procedure](#)).

Operation is performed from the control room of the higher-level facility or from the local control point. The safety systems and safety instructions in the operating instructions for the higher-level plant/machine must be adhered to.

The area around the plant/machine and the operator work stations at the plant/machine must be kept free of objects during operation so that unobstructed access is possible at all times.

When operating the device, adhere to the following additional instructions:

Operation of the device without cleaning medium is not permitted and is only permitted for a limited time for certain situations without cleaning medium.

Basic requirements:

- When switching on: First supply the cleaning medium, then switch on the actuator!
- When switching off: First switch off the actuator, then interrupt the cleaning medium!

Operation of the device without cleaning medium (cleaning head rotates):	Max. 5 minutes
Dry blowing of the device with non-flammable gaseous medium (e.g. air or nitrogen):	Max. 5 minutes
Sterilize the device with steam at 121.1 °C (250 °F) when at rest:	Max. 20 minutes

Table 6.4-1: Time-limited Operation of the Device without Cleaning Medium

⚠ WARNING Persons in the container. Persons may be struck by the jets from the cleaning head!

There is a risk of death or severe physical injury.

- Do NOT start the cleaning process while there are persons in the container.
- NEVER direct the cleaning jet or torrent at persons.

⚠ WARNING Incorrect operation of the device!

There is a risk of death or severe physical injury.

- Only operate the device when it is in perfect condition.
- Do not operate the device unless it is installed inside a closed container.
- Drain and depressurize the container that needs to be cleaned.
- Securely close all of the openings on the container (e.g. inspection openings).
- When operating the device, **adhere to the switch-on and switch-off procedures** (see [Sections 6.3 Switch-on Procedure](#) and [7.2 Switch-off Procedure](#)).
- There is no need for the device to be run in.
- The following operating states of the device are NOT permitted:
 - Operation of the device without cleaning medium.
 - Immersing the device in the product of the production process.
 - Operation of the device outside the permitted parameters (see [Section 3.3 Technical Data](#)).
- Immediately stop operation in the event of leaks outside the container.
- Refrain from any type of work which compromises the safe and reliable function of the device.
- Immediately inform the operating company of any changes to the device or the plant that may impair its safety.

If you notice vibrations on the plant that are NOT generated by the device while commissioning the device, these must be prevented with suitable measures so that the vibrations CANNOT be transmitted to the device.

If this is NOT possible, the maintenance intervals must be shortened in accordance with [Section 7.4.1 Maintenance Intervals](#).

During normal operation of the device, you must make sure that the mixture of supplied cleaning medium and dislodged substances can flow freely from the container.

NOTE Clogging in the drain of the container is to be eliminated at once so that:

- no large quantities of dirt can accumulate in the container,
- there is NO impermissible filling of the container with cleaning medium,
- the device does NOT become immersed as the fluid level rises.

For cleaning media in circulation:

Run the final cleaning step with clean water to remove any suspended matter which may have been introduced.

7 Maintenance

The following safety instructions apply to all work on the device that is listed and described in this chapter, and must be observed at all times.

Only use **original spare parts** when replacing parts of the device. A **functional check** must be performed after all maintenance work (see [Section 6.2 Functional Check/Trial Run](#)).



If you have questions or doubts about handling the cleaning device, please contact AWH.

7.1 Safety Instructions for Maintenance



DANGER



Danger to life due to live components!

Activated electrical components are live with dangerous electrical voltage and may perform uncontrolled movements. An electric shock may occur from coming into contact with these components.

There is a risk of death or severe physical injury.

- Allow only **qualified electricians** to perform work on the electrical system.
- Before starting work, observe the **work steps of the switch-off procedure** (see [Section 7.2 Switch-off Procedure](#)).
- Cover adjacent live parts to prevent contact.
- Beware of the hazards caused by electrical current (e.g. warnings).



WARNING



Risk of falling when working at heights!

When carrying out assembly/disassembly work on parts of the plant at heights, there is a risk of falling.

There is a risk of death or severe physical injury.



- Do not perform any work at heights except with a safety platform with cage or suitable fall protection (e.g. safety rope and safety harness).
- If you are using a harness as fall protection, it is imperative that the rescue concept for a person in the harness is observed.
- A person must not remain suspended in the harness for longer than 15 min as there is otherwise a risk of shock or even death.
- Wear protective work clothing, safety shoes, protective gloves and a hard hat for work at heights.

**WARNING*****Risk of accident caused by incorrectly performed maintenance and repair work!***

Improper maintenance, falling components or failure to adhere to the listed safety instructions can lead to accidents.

There is a risk of death or severe physical injury.

- Only allow experts to perform work on the device.
- Do not work on the device unless it is disconnected from the power supply, depressurized and in a cool state.
- Maintain a safe distance when working on the device.
We recommend that you provide 1 m of space for free movement around the device and container.

**WARNING*****Risk of chemical burns and heat burns when opening the container!***

The supply line is pressurized. The person may be struck by cleaning jets or come into contact with residual fluid from the supply line and device. There may also be hot vapors in the container.



There is a risk of death or severe physical injury.



- **Do NOT open the container** during the cleaning process.
- Before starting work, observe the **work steps of the switch-off procedure** (see [Section 7.2 Switch-off Procedure](#)).
- Before opening the container, observe the **cooling and draining time**.
- Use personal protective equipment (e.g. protective gloves, safety shoes, safety goggles).

**WARNING*****Danger due to hot surfaces!***

The device may heat up significantly as a result of the cleaning medium or the heat transfer from the container. Contact with the device can cause burns to the skin.



There is a risk of burns from the cleaning medium at temperatures above +60 °C (+140 °F).

- Do not remove the devices unless they are in a cool state.
- Allow the device to cool down before starting work.
- Beware of hot surfaces (e.g. warning signs).
- Use safety clothing and equipment (e.g. protective gloves, cloths) to provide protection against the hot surface.

 **WARNING****Risk of crushing when carrying out maintenance, cleaning and repair work!**

The container and the interfaces of the device (e.g. media connections) may be pressurized.



There is a risk of death or severe physical injury.

- Before starting work, depressurize the container and all lines.
- Switch off all moving parts in the container and secure them to prevent them from being inadvertently switched back on or set in motion.
- Do not remove the device unless it has been depressurized.
- Wear protective gloves.

 **WARNING****Danger of crushing being drawn into the equipment due to inadvertent starting-up of the actuator!**

Danger could arise from a sudden, unforeseeable return of energy supply (e.g. unauthorized switching back on).

There is a risk of death or severe physical injury.

- Switch off the energy supply (e.g. electricity or compressed air) before all maintenance, cleaning or repair work.
- Before starting work, adhere to the **work steps of the switch-off procedure** (see [Section 7.2 Switch-off Procedure](#))

7.2 Switch-off Procedure

In accordance with the type of device activation and how it is integrated (e.g. manual or automatic) on the cleaning plant, the switch-off procedure must be integrated and the following instructions must be observed when switching off.

 **WARNING****Danger due to sudden, unexpected or unauthorized reactivation of the device!**

For example, a start command can be triggered by incorrect operation of a start control device. For a safe cleaning process it is absolutely necessary to consistently follow the sequence of safety-relevant switching processes. Non-compliance prevents operational safety, thus leading to hazards.

- Before performing any disassembly, maintenance, repair or cleaning work on the device, it is imperative to carry out the following **work steps** in the specified order.

SWITCH-OFF PROCEDURE**Work Steps**

1. *Cut off the supply of electric power or compressed air to the actuator of the device.*
 - *Check that the energy supply is interrupted and that no more energy (also no residual energy) is present on the device and thus that the device is deenergized and depressurized.*
2. *Secure access to the supply of energy to the actuator to prevent sudden, unforeseeable or unauthorized reactivation (e.g. lockable switch/shut-off elements).*
3. *Shut off the supply of the cleaning medium.*
 - *Slowly stop the pump and close the shut-off fitting (e.g. valve or ball cock).*
 - *Check that the supply of cleaning medium is stopped (e.g. flow meter) and there is no media pressure on the device.*
4. *Safeguard the supply of cleaning medium to prevent sudden, unforeseeable or unauthorized reactivation (e.g. lockable switch/shut-off elements).*
 - *Check that any supply of media is reliably prevented and insert dummy disks if necessary. Observe a cooling-down phase for media temperatures above 80 °C.*
 - *Make sure that the cleaning device and supply line for cleaning medium have been completely drained (e.g. by waiting before opening the container).*
5. *Depressurize the container against the ambient pressure.*
 - *Safeguard the supply of steam or other media that affect the pressure to prevent sudden, unforeseen or unauthorized reactivation (e.g. lockable switches/shut-off elements).*
 - *Make sure that the pressure inside the container matches the ambient pressure.*

NOTE***Risk of breakage due to material overload!***

Pressure surges when switching the cleaning medium on or off, in particular pressure surges that exceed the operating pressure, and gas components in the cleaning medium can cause hammering in the cleaning device.

There is a risk of material damage, e.g. leakage in the pipe system or on connected devices.

- *Prevent pressure surges ("water hammers") and gas components in the cleaning medium, e.g. caused by:*
 - *installing a water hammer arrester or pressure relief valve in the supply line,*
 - *starting/stopping the pump slowly and*
 - *opening/closing the shut-off fitting slowly (e.g. valve or ball cock).*

7.3 Removal

The safety instructions in [Section 7.1 Safety Instructions for Maintenance](#) must be observed before removing the device from the container.

WARNING



Risk of chemical burns and heat burns when opening the container!

The supply line is pressurized. The person may be struck by cleaning jets or come into contact with residual fluid from the supply line and device. There may also be hot vapors in the container.



There is a risk of death or severe physical injury.



- **Do NOT open the container** during the cleaning process.
- Before starting work, observe the **work steps of the switch-off procedure** (see [Section 7.2 Switch-off Procedure](#)).



- Before opening the container, observe the **cooling and draining time**.
- Use personal protective equipment (e.g. protective gloves, safety shoes, safety goggles).

CAUTION



Risk from protruding sharp edges on the device!

Depending on the design, the device may have protruding sharp edges which can be dangerous when handling it.

There is a risk of minor cuts.

- Wear protective gloves when working on the device.
- When handling, e.g. unpacking, transportation without packaging, assembly/disassembly and maintenance work, beware of protruding sharp edges.

CAUTION

Fault as a result of dirt, foreign objects or damage to the device!

Foreign objects such as scale, burrs, chips, etc. can restrict flow or get into the piping system and cause malfunctions or damage to components, including gaskets. This can result in hazards that endanger the functional safety of the device.

There is a risk of minor or moderate injuries.

- Implement suitable measures to prevent dirt and foreign objects from entering via the interfaces of the device.
- Before starting work, make sure that all necessary tools, auxiliary materials and information are available and observe the instructions for the interfaces.
- When lifting the device out of the container, maintain a distance from the inner wall of the container and surrounding components (e.g. agitators), to avoid scraping or knocking.
- Set the device down on a stable surface after removing it.

7.3.1 Removing the Device

Installation Opening of the Container

The intended use of the device (mobile or stationary) is the decisive factor for the required size of the installation opening. The specified installation dimensions in [Table 3.3-1: Operating Parameters of the Device \(Standard\)](#) are recommended minimum dimensions for the installation opening and for installing the device in the container and removing it from the container in assembled condition.



We recommend using two people for assembly/disassembly.

⚠ WARNING Risk of the device falling accidentally!

The device may strike personnel when falling.

There is a risk of severe physical injury.

- Hold the device firmly when installing/removing it.
- There must be nobody beneath the device when installing/removing it.

Interface A

Before mechanically detaching the device from the container, first properly disconnect the motor from the power supply. Any work must be carried out exclusively by qualified personnel on a stationary motor in a state where it is disconnected and secured against being switched on again.

⚠ WARNING Danger due to improper disconnection from the power supply!

Various sources of danger can arise if the procedure is not carried out correctly.

- The connections and lines of the electric motor (e.g. terminal box) may be carrying electrical voltage. This may result in an electric shock.
- The connections and lines of the air motor (e.g. plug-in couplings) may be under pressure! A mechanical shock may occur due to whipping of a compressed air hose.
- The connections and lines of the cleaning medium may be under pressure! Hot and/or corrosive fluid may spray out.

There is a risk of death or severe physical injury.

- Before performing any work on the device, follow the switch-off procedure (see [Section 7.2 Switch-off Procedure](#)) and allow the device to cool down.

A1 Connections for the electrical or pneumatic actuators are to be disconnected in accordance with the specifications contained in the documentation supplied by the respective manufacturer. Consistently observe the connection conditions of the actuator manufacturer.

A2 Disconnect the supply line for the cleaning medium disconnected at the media connection [MC]. Close the media connection [MC] with a suitable screw cap/sealing plug.

A3 If the rinsing connection [RC] is connected, disconnect the discharge line and close the rinsing connection [RC] (e.g. blind plug).

Interface B

NOTE Excessively small installation opening on the container!
Damage to the device or its surroundings may result.

- Before unfastening interface B, check whether the device can be lifted out through the installation opening of the container with the cleaning head (see [Section 3.3 Technical Data](#)).
- The instructions for interface "C" must be observed if the installation opening is too small.
- The process connection must be disconnected from the container connection depending on the version. For more information on the connections, see [Section 3.1.1 Special Designs](#).

B0 without process connection [PC] (special design)

B1 Process connection [PC] permanently welded (standard design)

B2 Process connection [PC] movable (special design)

Interface C

⚠ CAUTION Excessively small installation opening for the container or components (e.g. agitators) in the container!

Nozzles collide during removal.

The nozzle carrier may come loose or damage to the device may result.

- The nozzles must NOT collide!
 1. Check the following before pulling the device out of the container:
 - The minimum dimension for the installation opening (see [Section 3.3 Technical Data](#)),
 - Check for interfering contours on surrounding components in the container.
 2. Lift the device (downpipe [DP] with cleaning head) out of the container through the installation opening with the utmost care.

Removing the Stationary Device

A "stationary device" can be removed in different ways depending on the properties of the container and the size and accessibility of the installation opening:

- Before removal, the downpipe [DP] is disconnected from the process connection [PC] and lifted out of the container through the installation opening from the outside, together with the cleaning head.
- The cleaning head is detached from the downpipe [DP] of the device from inside the container and the device is lifted out of the container without the cleaning head from the outside through the installation opening. After that, the cleaning head is reattached to the downpipe [DP] of the device.

NOTE The following must be noted regarding the installation opening:

- Align the nozzles by:
 - Powerfully rotating the "bottom of the housing (2.11)" on the cleaning head in the direction of the arrow, or
 - Briefly starting up the actuator.

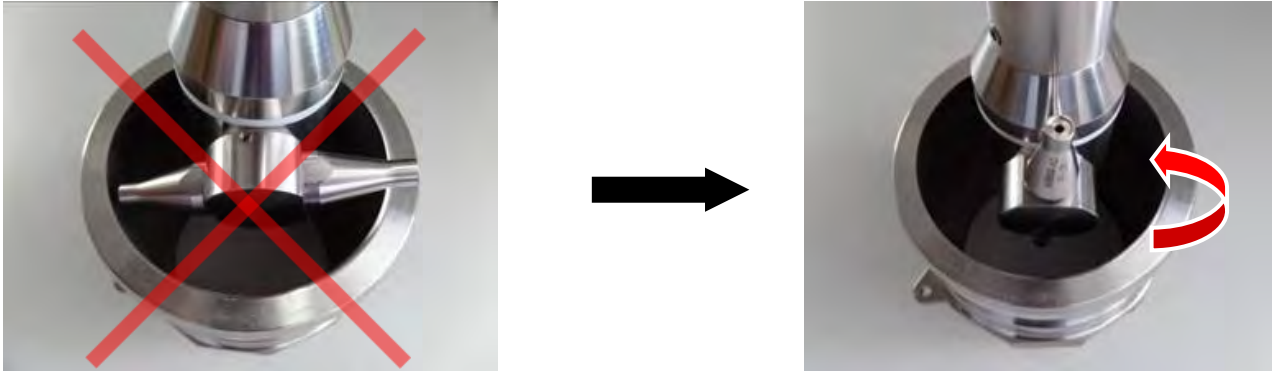

Figure 7.3-1: Nozzle Position Stationary Device

- Alternatively, unscrew the cleaning head from the downpipe [DP] inside the container and screw back on again after removing the device (see [Section 7.4.3.2 Disassembly – Head AG](#)).

Removing the Mobile Device

⚠ CAUTION If the device (downpipe [DP] with cleaning head) is used within the effective range of internal fittings, there is a possibility of collision with moving internal fittings (e.g. agitators) in the container! Various faults or impermissible operating states can occur.

Material damage and consequential damages may occur.

- Monitor the defined resting positions of movable internal fittings and secure them against restarting until the device (downpipe [DP] with cleaning head) is no longer within the effective range of internal fittings or has been removed from the container. Only then may the process be restarted after the cleaning process has been completed.

7.4 Maintenance

To ensure the trouble-free operation, high operational safety and long service life of the cleaning device, it is imperative to have it cleaned and maintained at regular intervals.

All maintenance, repair and assembly/disassembly work for individual components and assembly groups should only be carried out when the device is in its disassembled state.



We recommend that you document the maintenance work in a report.

The safety instructions in [Section 7.1 Safety Instructions for Maintenance](#) must be adhered to when carrying out cleaning, maintenance and repair work.

WARNING***Danger due to the magnetic field of the magnetic coupling!***

Magnets generate a wide-ranging, strong magnetic field. Among other things, they can damage devices (e.g. televisions, laptops, computer hard drives, data carriers, credit and EC cards, clocks, hearing devices and loudspeakers).

Magnets can cause malfunctions for individuals with cardiac pacemakers and/or serious endangerment of their health.

There is a risk of death or severe physical injury.

- Personnel with cardiac pacemakers may NOT assemble or disassemble the device.
- Maintain a minimum safety distance of at least 0.5 m between magnet carriers/magnets in the device and objects and technical devices whose function can be impaired by magnetic fields.

CAUTION***Danger of crushing during maintenance work on the device in the area of the magnetic coupling!***

Magnets have powerful attractive forces. Careless handling can cause fingers or skin to be crushed or pinched.

There is a risk of minor or moderate bodily injury.

- When assembling and disassembling the device in the area of the magnetic coupling, take special care with tools that have magnetic properties.
- Do NOT bring magnet carriers/magnets close to substances or objects that have magnetic properties.
- Always store magnet carriers/magnets separately with a safety distance of 0.5 m.

NOTE***Risk of damage to the device due to improper assembly/disassembly work!***

Assembly/disassembly of the device that is NOT performed properly could cause damage to the device and put its functional safety and reliability at risk during recommissioning.

The failure of components or a device malfunction can cause material damage and consequential damages.

- Use a vise with protective jaws, e.g. plastic or light metal, for clamping.
- Only use suitable tools that do not damage the surface.
- For assembly work, adhere to the specified tightening torques (see [Section 7.5 Spare Parts and Customer Service](#)).

NOTE***Risk of dirt and foreign objects in the device!***

Dirt or foreign objects can impair the functional safety and reliability of the device.

- *During assembly, make sure and check that there is no dirt or foreign objects in the device (e.g. small particles, sealing material).*

NOTE***Damage to the screw connections!***

Stainless steel screw connections may tend to seize up during assembly as a result of friction caused by high preload forces and high friction values, and can cause problems when tightening and releasing.

- *Lubricate the screw connections before assembly.*
- *Define the choice of lubricant very precisely for the application and the requirements (e.g. Klüberpaste UH1 96-402 or UH1 84-201).*
- *Adhere to the information on the safety data sheets provided by the lubricant manufacturer.*

NOTE***Edge compression in the area of the wrench flats!***

If workpieces are NOT grasped without play and in a protective manner by the flats during assembly/disassembly, then they are at risk of damage.

- *For gentle, protective assembly/disassembly work, use an adjustable or pliers wrench with parallel, smooth clamping jaws.*
- *Apply the clamping jaws of the adjustable wrench or pliers wrench to the flats without play so that they rest evenly across the surface and loosen or tighten the screwed part.*

Maintenance of the Control System and Equipment Parts

A control system and equipment parts (e.g. filter, shut-off fitting or flow meter for the cleaning medium), are NOT supplied by the manufacturer!

The intervals as well as methods for their maintenance work are to be determined by the operating company according to the specifications of the respective manufacturer and in accordance with the safety requirements.

7.4.1 Maintenance Intervals

NOTE

Component failure due to vibration damage!

During operation, vibration can cause screw and clamp connections to become loose or the device to be subjected to severe strain, thus possibly leading to component failure.

The failure of components or a device malfunction can cause material damage and consequential damages.

- *Check the installed device for loose connections at regular intervals.*
- *Pay attention to vibration damage during maintenance and inspection.*
- *Adapt the maintenance intervals according to the operating conditions of the plant. After commissioning, start with short maintenance intervals at first. If no damage occurs, the maintenance intervals can be adapted incrementally until the intervals specified in the instructions are reached.*

Maintenance Intervals and Methods



Shorten the maintenance intervals by 30% in the event of:

- Deviation from the preferred installation position of the device (see [Section 5.2.2 Installation Position](#)).
- Vibrations that occur in the plant which are NOT caused by the device and CANNOT be prevented.

If the device is NOT operated for a longer period, we recommend that you check the device completely before recommissioning to make sure that it is fully functional (see [Section 6.2 Functional Check/Trial Run](#)).



The specified times of the maintenance intervals are based on single-shift operation (8 hours per working day, 12 months per year) of the device and operation with

Cleaning medium: Water
 Media pressure: 8 bar (116 psig)
 Media temperature: 25 °C (77 °F)

Interval:	h ₀ = operating hours of the device	Method:	V = visual inspection
	d = daily		F = functional check
	w = weekly		M = measurement
	m = monthly		C = cleaning*
	¼ y = quarterly		
	½ y = every six months		
	y = yearly		

*The cleaning intervals are to be defined by the operating company in accordance with operating conditions.

Overview of Maintenance Points

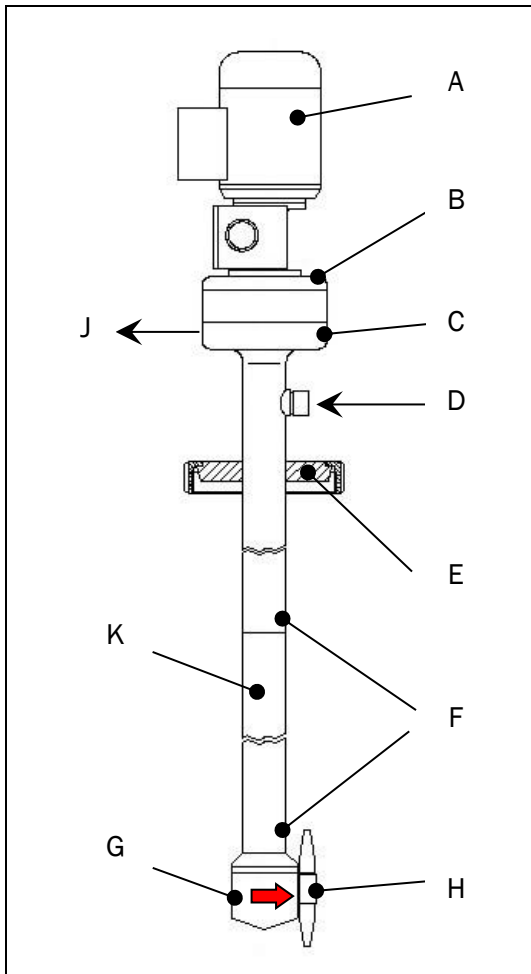

Maintenance Points

- A Actuator AG
- B Motor connection AG (with magnet carrier)
- C Downpipe AG (with magnet carrier)
- D Media connection [MC]
- E Process connection [PC]
- F Locking screws
- G Head AG without nozzle holder
- H Nozzle holder AG (nozzle carrier with nozzles)
- J Rinsing connection [RC] optional
- K Downpipe extension [DPE] AG

Figure 7.4-1: Maintenance Points



The tightening torques required for the screw connections are listed in [Table 7.5-5: Parts List for Motor Connection AG JX75 and JX80 \(Standard\)](#).

Point	Inspection and Maintenance Work	Interval	Method
A	<p>Check the correct and tight fit of the actuator AG, in particular the connection of the energy supply system (electric or compressed air line).</p> <ul style="list-style-type: none"> Observe the maintenance instructions in the actuator manufacturer's instructions. When returning the energy supply system, ensure the correct direction of rotation of the cleaning head (see Section 5.3.1 Direction of Rotation of Cleaning Head). 	m	V, F
B	<p>Check correct and tight fit of all screw connections of the motor connection AG.</p> <ul style="list-style-type: none"> Properly tighten loosened screw connections. 	m	V, F, M
C	<p>Check O-ring between sealing flange and downpipe flange of downpipe AG for leak tightness.</p> <ul style="list-style-type: none"> Ensure it is technically leakproof. 	½ y	V, F, C
	<p>Check ball bearing, thrust washer and locking ring for wear and damage.</p> <ul style="list-style-type: none"> Check the bearing movement. Replace parts in the event of wear or damage. 	100 h _o	V
	<ul style="list-style-type: none"> Replace the ball bearing, at the latest after a running time of 	400 h _o	F
D	<p>Check the media connection [MC] for leaks, wear and contamination. Check the upstream filter for function and contamination.</p> <ul style="list-style-type: none"> Clean or replace the filter. Ensure it is technically leakproof. 	m	V, F
E	<p>Check process connection [PC] for leaks, wear and contamination as well as correct and tight fit.</p> <ul style="list-style-type: none"> Check seal ring. Replace parts in the event of wear or damage. Remove contamination. Properly tighten loosened screw connections. Ensure it is technically leakproof. 	m	V, F
F	<p>Check tight fit of locking screws between downpipe AG <> (DPE AG optional) <> head AG.</p> <ul style="list-style-type: none"> Properly tighten loosened screw connections. 	m	V, F
G	<p>Check plastic bearings (bushings and sliding disks) for wear and damage. Replace, if necessary.</p> <ul style="list-style-type: none"> Check the bearing movement. Replace parts in the event of wear or damage. 	200 h _o	V
	<p>Check yoke coupling (setting nut, shaft with slot and driver pin of the shaft WA) for wear and damage.</p> <ul style="list-style-type: none"> Replace parts in the event of wear or damage. 	½ y	V, F

H	Check screw connections for correct and tight fit as well as the functioning of the head AG and the nozzle holder AG. <ul style="list-style-type: none"> Properly tighten loosened screw connections. 	m	V, F, M
J	Optional: Check the blind plug or discharge line of the rinsing connection [RC] for leaks, wear and contamination as well as correct and tight fit.	m	V, F, M
K	Optional: The DPE AG must be maintained at the same intervals as the basic device (see maintenance points C, F and G).		

Table 7.4-1: Inspection and Maintenance Work



Heavily worn bushings can cause increased wear on the spur gears in the area of the teeth.

7.4.2 Tools and Tightening Torques

Use only proper tools which are required for performing the required work and approved for use.

The following tools are required for mechanical work on the device:

- Set of screwdrivers (flathead/Phillips)
- Allen key
- Set of open-end wrench/ring wrenches
- Set of socket wrenches
- Pliers wrench, adjustable or crescent wrench with smooth parallel gripping jaws
- Torque wrench with socket shaft □ 14 x 18
- Torque screwdriver with inserts and accessories
- Strap wrench/belt pipe wrench (e.g. Ø 140) with woven belt
- Face wrench (adjustable pin spacing; pin diameter Ø 4 mm)
- Locking ring pliers for inner ring (hole diameter Ø 22 mm)
- Caliper (e.g. measuring range 150 mm)
- Distance-/feeler gauge (e.g. measuring range 0.02 – 1 mm)



Once the bushings have been changed, it may be necessary to use reamers for smoothing down:

Reamer H7 (Ø 10 mm or Ø 18 mm depending on the device).

All the screw connections on the device are firmly tightened in the factory with a corresponding tightening torque. This ensures that the required clamping force between the components to be joined is also present during the time of maximum application of operating forces.



All relevant tightening torques of the screw connections are listed in [Section 7.5 Spare Parts and Customer Service](#) in [Table 7.5-5: Parts List for Motor Connection AG JX75 and JX80 \(Standard\)](#).

The tightening torques for the electrical or pneumatic connections of the actuator can be found in the documentation provided by the respective manufacturer.



For proper disassembly and assembly of the device, protective jaws (e.g. made of plastic or light metal) are recommended for clamping the device in the vise.



7.4.3 Disassembling the Device

NOTE Foreign objects impair the functional safety of the device!

This can cause damage, mechanical sparks and/or hot surfaces in the device.

- Ensure that no foreign objects enter the device while you are working with it.



The tools required for assembly/disassembly work are listed in [Section 7.4.2 Tools and Tightening Torques](#).



A list of spare parts is provided in [Table 7.5-5: Parts List for Motor Connection AG JX75 and JX80 \(Standard\)](#).

7.4.3.1 Disassembly – Magnetic Coupling

⚠ CAUTION Danger due to magnetic field!

The magnetic carriers have powerful attractive forces.

Minor personal injury or damage to the device may result.

- Proceed with caution when working in the area of the magnetic coupling.

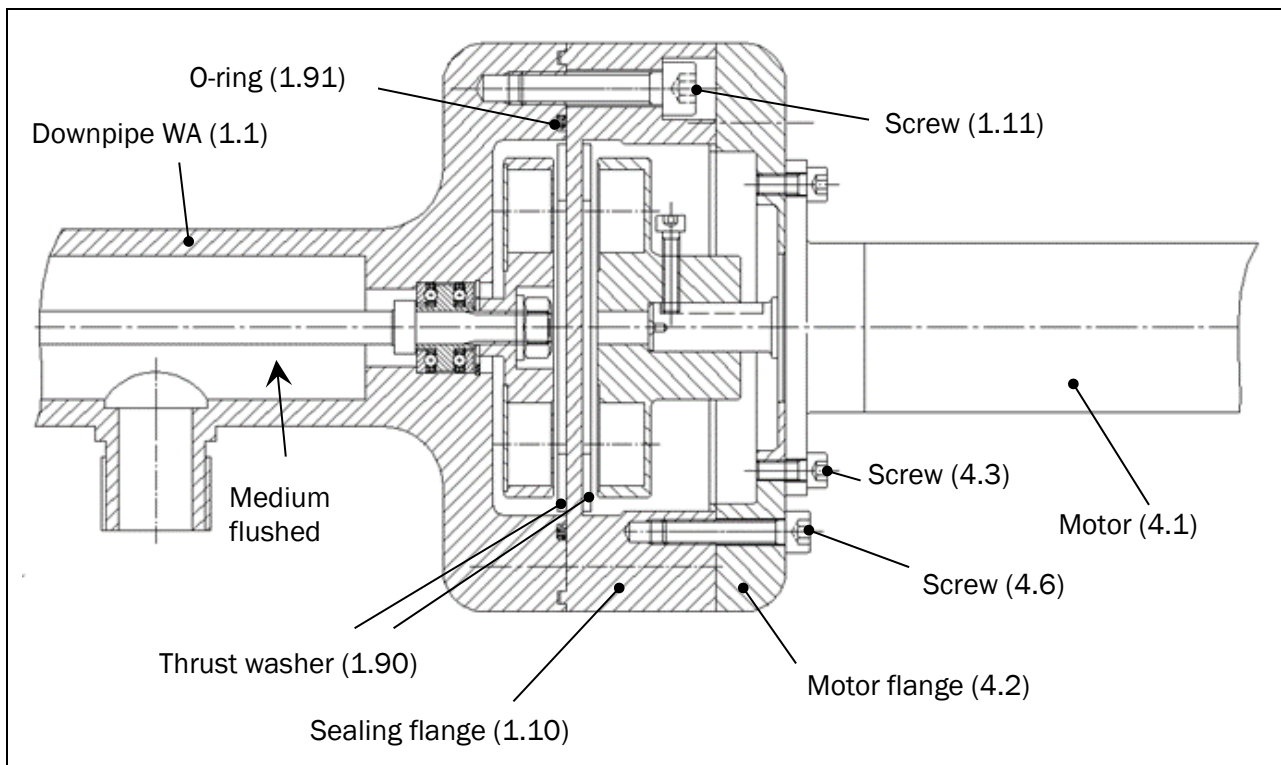

Figure 7.4-2: Magnetic Coupling

Disassembly – O-ring

1. Loosen and unscrew the screws (4.3).
2. Remove the motor (4.1) together with the motor flange (4.2) and the motor-side magnet carrier WA (4.4) and set aside safely.

3. Remove the thrust washer (1.90).
4. Loosen and remove the screws (1.11).
5. Remove the sealing flange (1.10).
6. Remove the thrust washer (1.90).
7. Remove the O-ring (1.91).
8. Replace O-ring (1.91) and mount device according to [Section 7.4.4](#) or continue with disassembly.

Disassembly – Motor Connection AG

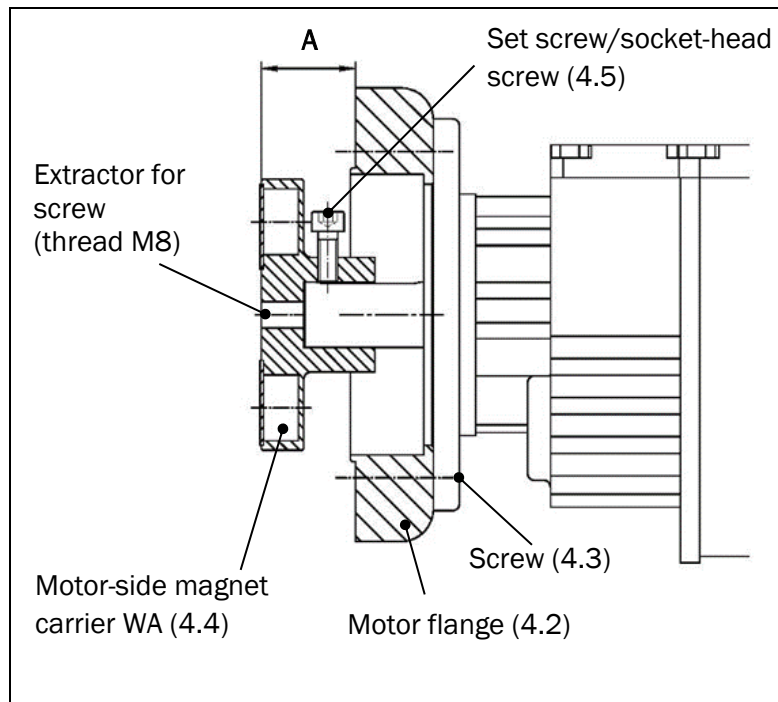

1. Loosen the set screw/screw (4.5) and unscrew it.
2. Pull motor-side magnet carrier WA (4.4) off the actuator shaft and set it down safely. If necessary, use an M8 screw as an extraction aid.
3. Loosen and unscrew the screws (4.3).
4. Remove the motor flange (4.2).

Figure 7.4-3: Disassembly Motor Connection AG

Disassembly - Axial Bearing

1. Dismantle the motor connection AG (4) (see [Disassembly – O-ring work steps 1 to 7](#)).
2. Dismantle the head AG (2) (see [Section 7.4.3.2](#) or [Section 7.4.3.3](#)).
3. Firmly clamp the downpipe WA (1.1) vertically in the vise. The groove for the O-ring (1.91) points upwards.
Recommendation: For long devices (EL > 750 mm), clamp the downpipe [DP] horizontally and support the end with a trestle.

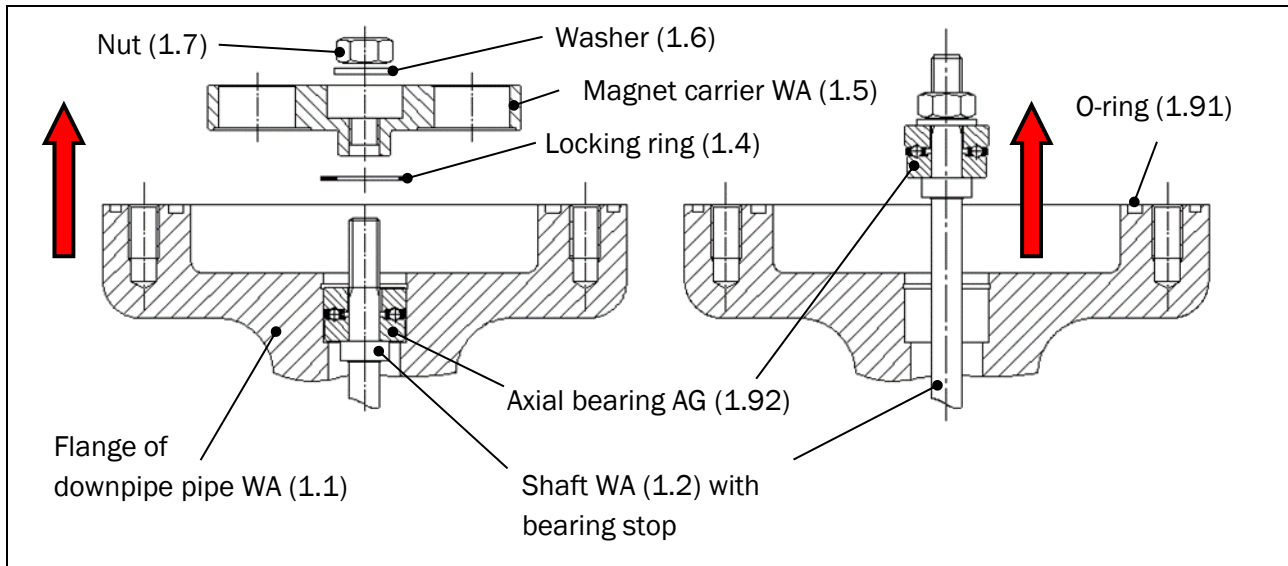

Figure 7.4-4: Disassembly Axial Ball Bearing

4. **⚠ CAUTION** Danger due to magnetic field!
The magnetic carriers have powerful attractive forces.
Minor personal injury or damage to the device may result.
 - Carefully insert the pins of the face wrench into the holes of the magnet carriers WA (1.5) and hold it tight.
 - Unfasten the nut (1.7) using a socket wrench and unscrew it from the shaft WA (1.2).
 - Remove the washer (1.6).
 5. **⚠ CAUTION** The shaft WA (1.2) can fall out!
Minor personal injury or damage to the device may result.
 - Secure the shaft WA (1.2) against falling out and unscrew the magnet carrier WA (1.5).
 6. Remove the locking ring (1.4) from the internal groove using locking ring pliers.
 7. Screw the nut (1.7) for securing the axial bearing AG (1.92) back onto the shaft WA (1.2) hand-tight.
- i** | A complete extraction of the shaft through the flange of the downpipe WA (1.1) is NOT possible with a shaft WA (1.2) with additional bearing for support (e.g. PTFE plain bearing).
8. Pull out the shaft WA (1.2) with the axial bearing AG (1.92) approx. 50 mm upwards and secure it against falling out.
 9. **NOTE** The balls of the bearing can fall out and get lost!
 - Unscrew nut (1.7) from shaft WA (1.2) and remove axial bearing AG (1.92).

7.4.3.2 Disassembly – Head AG

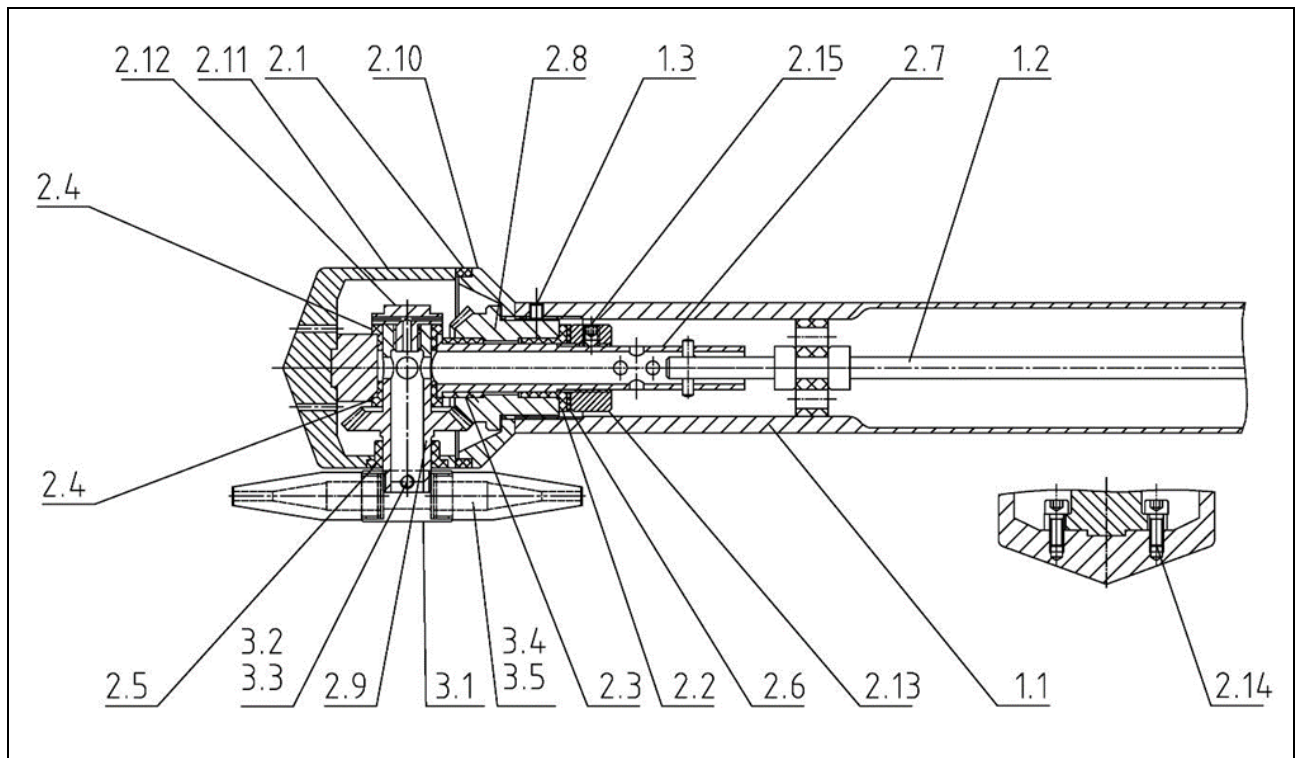

Figure 7.4-5: Cleaning Head with Individual Parts (Example TANKO-JX75)

1. Unscrew 2x set screws (1.3) and release housing top (2.10).
2. Unscrew head AG (2) from the downpipe WA (1.1).



While screwing the head AG (2), a perceptible skipping of the magnetic coupling is normal when the actuator is attached.

Disassembly – Bearing Bushings and Gear Wheels

1. Clamp the head AG (2) with the nozzle holder AG (3) firmly in the vise.
2. **NOTE** Edge compression in the area of the wrench flats!
Damage to the nozzles.
 - The wrench flat of nozzle (3.5) must protrude beyond the protective jaws.
 - Place the gripping jaws of the adjustable wrench or pliers wrench against the wrench flats without play and over the entire surface.
 - Unfasten and unscrew the nozzle (3.5) from the nozzle carrier (3.1).
 Remark: Repeat the steps depending on the number of nozzles

3. Unscrew 2x set screws (3.2) from nozzle carrier (3.1).



Loosen nozzle (3.5)

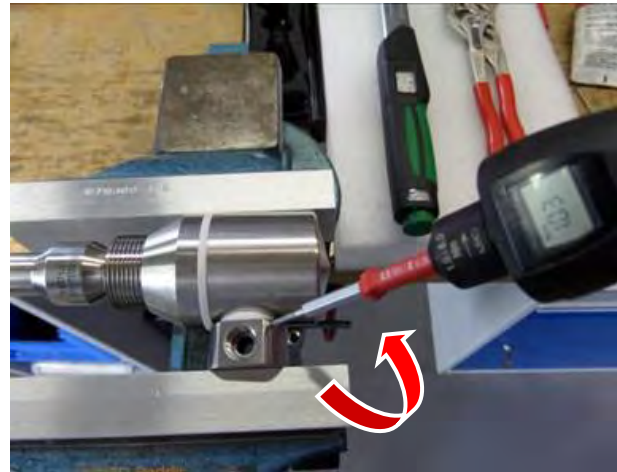

Loosen set screw (3.2)

4. Remove the head AG (2) with nozzle carrier (3.1) from the vise.
5. Unscrew housing top (2.10) and remove housing bushing (2.1).
6. Clamp the head AG (2) in the area of the shaft gear thread (2.8).
7. Secure setting nut (2.13) and shaft (2.7) with an open-end wrench to prevent them from turning.
8. Unscrew nozzle carrier (3.1).
9. **NOTE** (only for head AG JX70) The setting nut (2.13) is additionally secured against turning away from the shaft (2.7) by a dowel pin (2.16)!
 - Knock the dowel pin (2.16) out of the setting nut (2.13) using a mandrel (e.g. \varnothing 2.8 mm).
10. Unscrew 2x set screws (2.15) from setting nut (2.13).

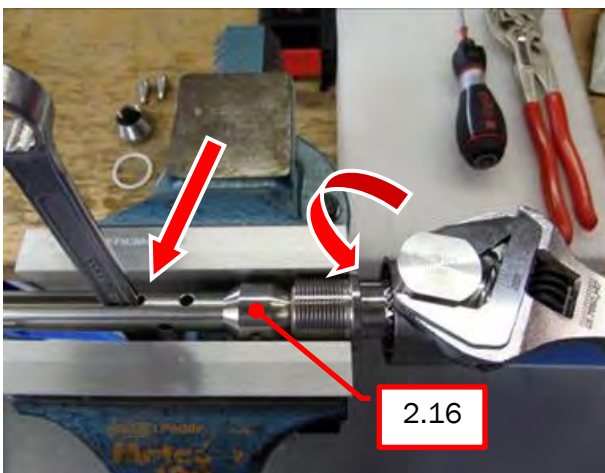

Unscrew nozzle carrier (3.1)



Loosen set screw (2.15)

11. Remove the head AG (2) from the vise.
12. Unscrew setting nut (2.13) from shaft (2.7).
13. Pull shaft gear (2.8) with bushing (2.2), bushing (2.3) and thrust washer (2.6) from the shaft (2.7).
14. Unscrew and remove 2x holding screws (2.14) from housing bottom (2.11).
15. Push collar bushing (2.5) out of housing bottom (2.11).

16. Remove shaft (2.7) with nozzle gear WA (2.9) and collar bushings (2.4) from the housing bottom (2.11) by tilting slightly.

17. **NOTE** Left-hand thread of the connection!

Turning the incorrect direction can damage the screw connection.

- Make sure that the screw connection is turned in the correct direction "LH" (left-hand).
- Block nozzle gear WA (2.9) using shaft gear (2.8).
- Loosen the flush bolt (2.12) with the correct direction of rotation.



Loosen holding screw (2.14)

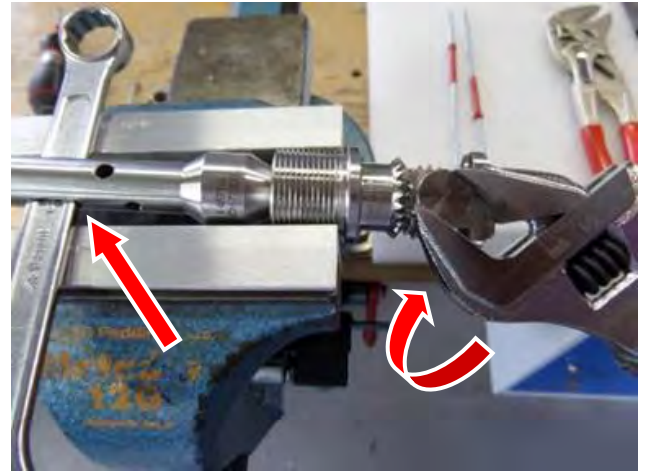

Loosen flush bolt (2.12)

18. Unscrew nozzle gear WA (2.9) from shaft (2.7).

19. Remove bushings (2.1, 2.2, 2.3 and 2.4), thrust washer (2.6) and shaft gear (2.8).

Change – Nozzles and Jet Concentrators

To replace the nozzles (3.5), proceed as described under [Disassembly – Bearing Bushings and Gear Wheels, work steps 1 to 2](#).

The spray concentrators (3.4) can then be pulled out of the nozzles (3.5) and replaced.

7.4.3.3 Disassembly – Head AG with JX80/70 Adapter

1. Loosen 2x set screws (1.3) on downpipe WA (1.1) and unscrew.
2. Loosen head AG with adapter (2) on the AF41 using an adjustable wrench or pliers wrench. Remark: Loosen older versions without AF using a belt pipe wrench.



Loosen set screw (1.3)

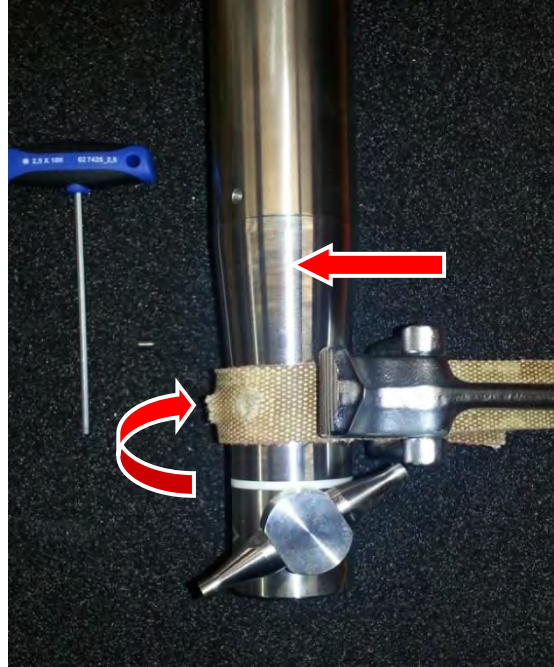

Loosen head AG (2) using a belt pipe wrench

3. Unscrew the head AG with adapter (2) from the downpipe WA (1.1).
4. Pull head AG with adapter (2) with fork of setting nut (2.13) from the shaft WA (1.2).



Unscrew head AG with adapter (2)



Pull out head AG with adapter (2)



While screwing the head AG (2), a perceptible skipping of the magnetic coupling is normal when the actuator is attached.

7.4.4 Assembling the Device

NOTE Foreign objects impair the functional safety of the device!

This can cause damage, mechanical sparks and/or hot surfaces in the device.

- Ensure that no foreign objects enter the device while you are working with it.



The tools required for assembly/disassembly work are listed in [Section 7.4.2 Tools and Tightening Torques](#).



A list of spare parts is provided in [Table 7.5-5: Parts List for Motor Connection AG JX75 and JX80 \(Standard\)](#).

7.4.4.1 Assembly – Magnetic Coupling

⚠ CAUTION Danger due to magnetic field!

The magnetic carriers have powerful attractive forces.

Minor personal injury or damage to the device may result.

- Proceed with caution when working in the area of the magnetic coupling.

Assembly – Motor Connection AG

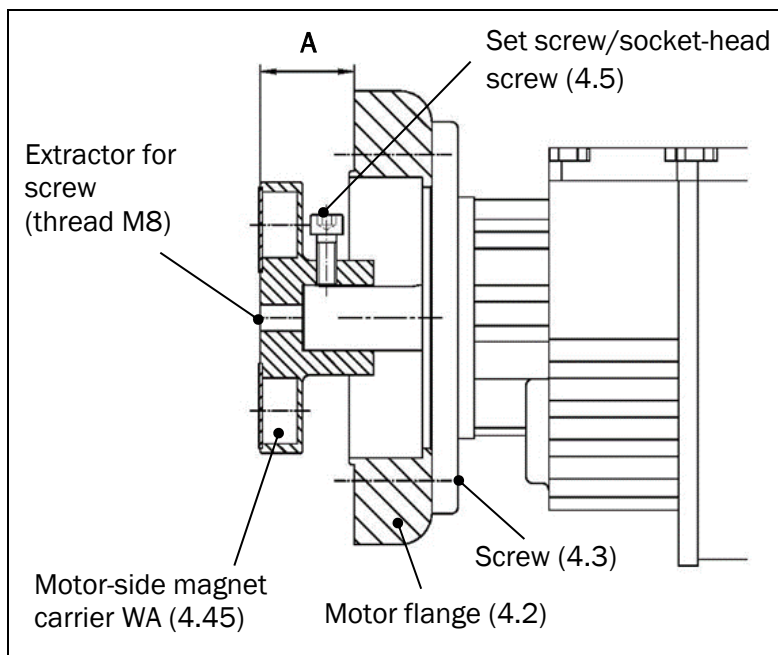

TANKO-JX	A = [mm]
70	25 ±0.5
75	29 ±0.5
80	29 ±0.5

NOTE For tightening torques of the screw connections, see [Section 7.5.1 Spare Parts for JX Standard \(Table 7.5-4 and Table 7.5-5\)](#).

Figure 7.4-6: Adjustment Dimension for Magnet Carrier (Motor Side)

1. Place the motor flange (4.2) on the counter flange of the actuator and align the holes.
2. Insert the screws (4.3) through the counter flange of the actuator, screw them into the motor flange (4.2) and tighten them evenly crosswise.
3. Push the motor-side magnet carrier WA (4.4) onto the shaft of the actuator and set the dimension "A" with a caliper.
4. Screw set screw/screw (4.5) into the motor-side magnet carrier WA (4.4) and tighten firmly.

Assembly – Axial Ball Bearing

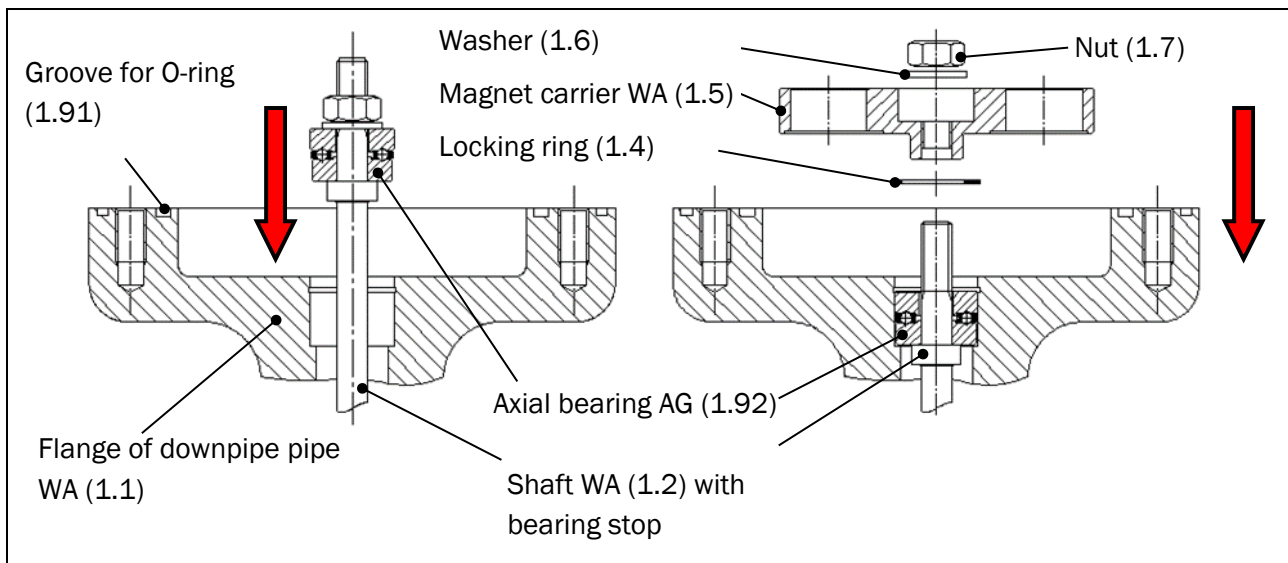

Figure 7.4-7: Assembly Axial Ball Bearing



The ball bearing does NOT require additional lubrication!

During operation, the balls of the axial bearing AGs (1.92) are rinsed by the cleaning medium and thus simultaneously lubricated and cooled.

1. **⚠ CAUTION** The shaft WA (1.2) can fall out!
Minor personal injury or damage to the device may result.
 - Push the shaft WA (1.2) from the head side of the device through the downpipe WA (1.1) into the hole of the downpipe flange bearing holder, so that the bearing stop of the shaft WA (1.2) protrudes approx. 50 mm.
 - Secure shaft WA (1.2) against falling out.
2. Downpipe WA (1.1) with shaft WA (1.2) firmly clamped vertically in the vise. The groove for the O-ring (1.91) points upwards.
Remark: For very long devices, clamp the downpipe horizontally and support the end with a safety stand.
3. **NOTE** Balls of the bearing can fall and get lost!
 - Push the preassembled axial bearing AGs (1.92) onto the shaft WA (1.2) up to the bearing stop.
Remark: In the case of a single row axial bearing AG 1, first slide the bearing washer with the smaller outside diameter!
 - Screw the nut (1.7) for securing the axial bearing AG (1.92) hand-tight onto the shaft WA (1.2).
4. Push the axial bearing AG (1.92) with shaft WA (1.2) up to the stop in the bearing seat of the flange of the downpipe WA (1.1).
5. **⚠ CAUTION** The shaft WA (1.2) can fall out!
Minor personal injury or damage to the device may result.
 - Secure shaft WA (1.2) against falling out.
6. Remove nut (1.7) from shaft WA (1.2).
7. Insert the locking ring (1.4) into the internal groove using locking ring pliers and snap it into place.

8. **⚠ CAUTION** Danger due to magnetic field!

The magnetic carriers have powerful attractive forces.

Minor personal injury or damage to the device may result.

- Screw the magnet carrier WA (1.5) onto the shaft WA (1.2).
- Slide the washer (1.6) onto the shaft WA (1.2).
- Screw the nut (1.7) into the shaft WA (1.2).
- Carefully insert the pins of the face wrench into the holes of the magnet carrier WAs (1.5) and hold it tight.
- Tighten nut (1.7) firmly with socket wrench and torque wrench.



The axial bearing AG (1.92) must be able to move freely!

For a single-row "Axial bearing AG 1" (1.92) (old version):

- *after screwing the magnet carrier WAs (1.5) onto the shaft WA (1.2), loosen the magnet carrier WAs (1.5) again by $\frac{1}{4}$ to $\frac{1}{2}$ turn and lock them with the washer (1.6) and nut (1.7).*

9. Functional check of the free rotary movement magnet carrier WA (1.5) with shaft WA (1.2).

Assembly – O-ring

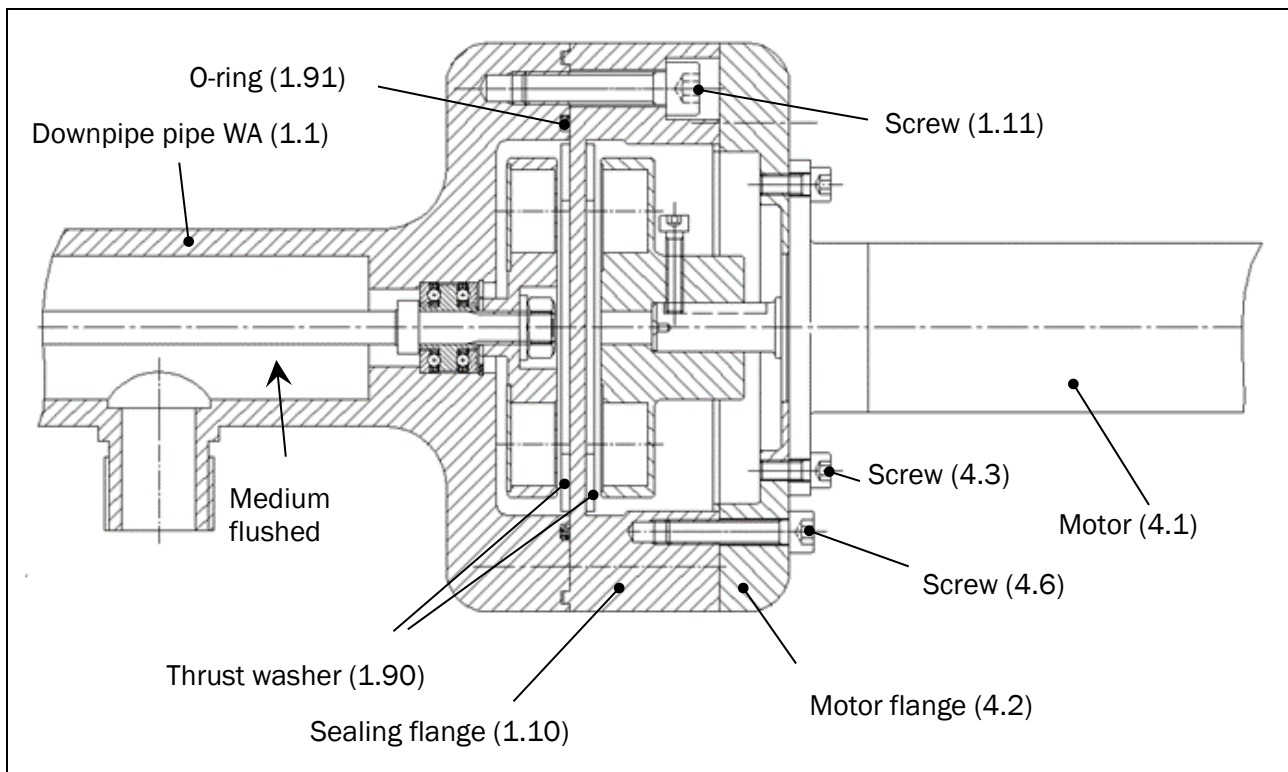

Figure 7.4-8: Magnetic Coupling

1. Insert the O-ring (1.91) into the groove.
2. **NOTE** If there is no thrust washer (1.90), the emergency running properties of the device are NOT guaranteed!
This can result in damage to the device.
 - Place the thrust washer (1.90) onto the magnet carrier WAs (1.5).
3. Place the sealing flange (1.10) and position it so that the through holes are aligned with the threaded holes of the flange of the downpipe WA (1.1).
4. **NOTE** Uneven tightening can cause the O-ring (1.91) to be squeezed asymmetrically!
Damage or leaks can be the result.
 - Insert screws (1.11) and tighten them evenly crosswise in 3 stages.
 - I. Tighten the screws by hand and ensure that the sealing surfaces are parallel!
 - II. Pre-tension screws crosswise.
 - III. Tighten the screws crosswise with torque.
5. **NOTE** If there is no thrust washer (1.90), the emergency running properties of the device are NOT guaranteed!
This can result in damage to the device.
 - Place thrust washer (1.90) in the sealing flange (1.10).
6. Position motor (4.1) together with motor flange (4.2) and motor-side magnet carrier WA (4.4) on sealing flange (1.10).
7. Insert the screws (4.3) and tighten them evenly.

7.4.4.2 Assembly – Head AG

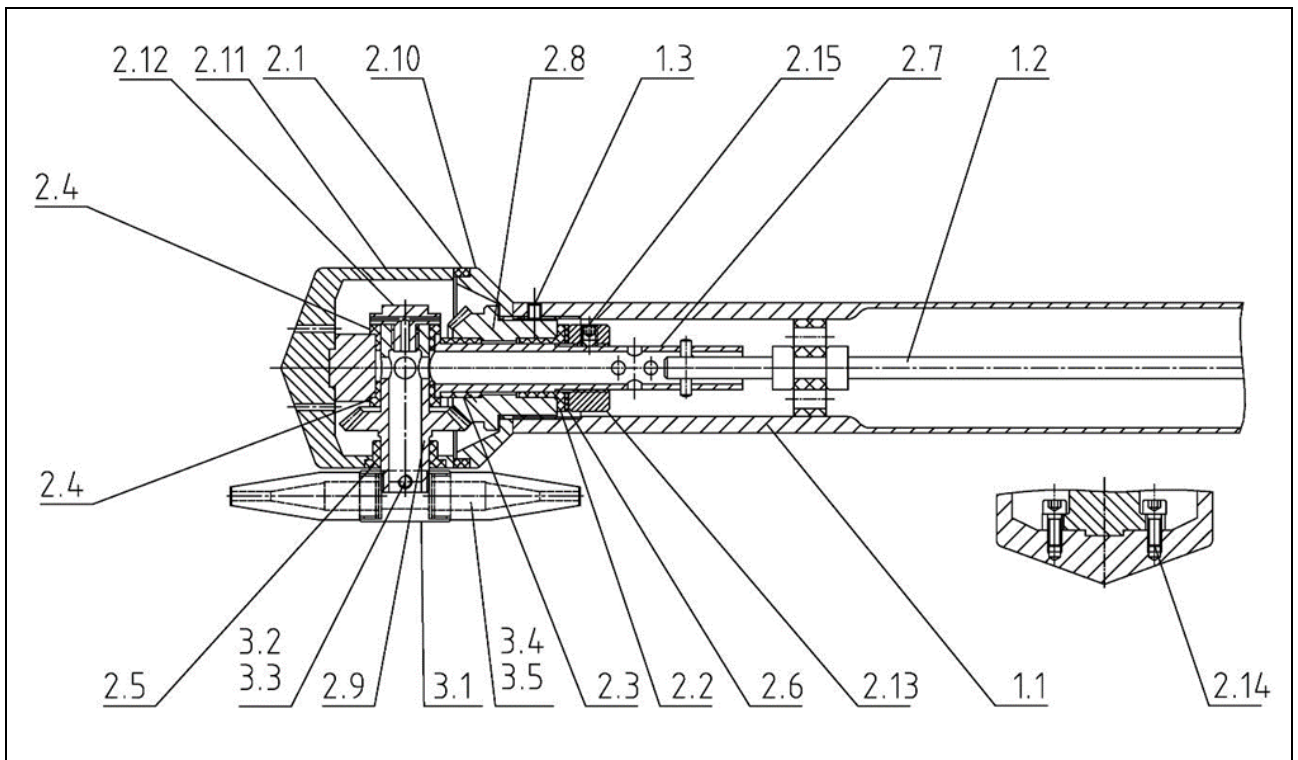

Figure 7.4-9: Cleaning Head with Individual Parts (Example for TANKO-JX75)



The bushings do NOT need additional lubrication!

The bushings are self-lubricating and are additionally wetted by the cleaning medium during operation and thus simultaneously lubricated and cooled.

The securing of the screw connection between the head AG (2) and the downpipe AG (1) for the TANKO-JX70 device has a special design feature (see Figure 7.4-10).

The required threaded holes 2x M5 for the set screws (1.3) are completed during the manufacture of the device only after the gap dimension of 0.1 to 0.2 mm between the housing bushing (2.1) and the housing top (2.10) has been set.

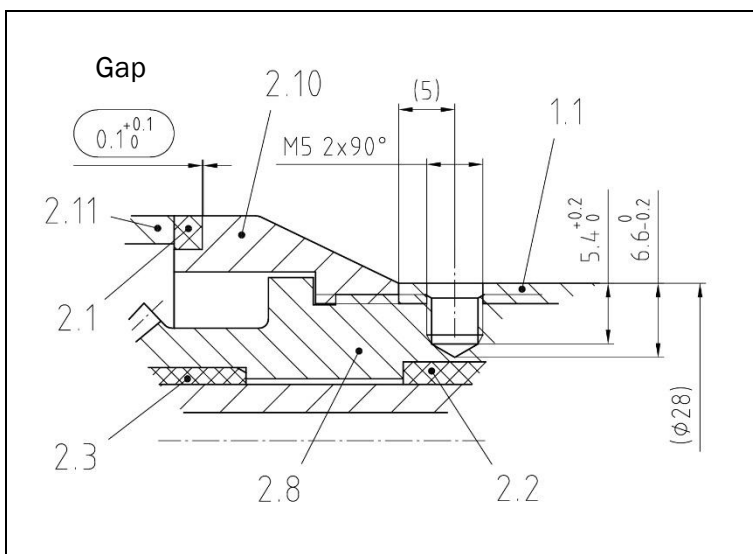

When the required gap dimension for the mobility of the head AG (2) has been set with a distance/feeler gauge, 2x holes are cut (Ø 4.2 mm offset by 90° 6.6 mm deep) using a milling cutter according to the pre-drilled downpipe WA (1.1) in the shaft gear (2.8). Then, the M5 thread is cut 5.4 mm deep with a blind hole tap.

Figure 7.4-10: Head AG JX70 (Screw Connection with the Downpipe AG)

In this way, the positions of the threaded holes are specific to each TANKO-JX70 device. This must always be considered when replacing the following components:

- Head AG (2) without threaded holes in the shaft gear (2.8)
- Shaft gear (2.8) without threaded holes
- Downpipe WA (1.1) with 2x holes pre-drilled 90° offset

Assembly – Bearing Bushings and Gear Wheels



So the shafts can turn freely, lightly rub the replacement bushings once installed with a reamer, if necessary. Avoid excessive smoothing, because it leads to increased leakage.

1. Replace bushings (2.1, 2.2, 2.3 and 2.4), thrust washer (2.6) and shaft gear (2.8) with new parts.
2. Push the nozzle gear WA (2.9) through the bushings (2.4) into the shaft (2.7).
3. **NOTE** Left-hand thread of the connection!
Turning the incorrect direction can damage the screw connection.
 - Make sure that the screw connection is turned in the correct direction "LH" (left-hand).
 - Block nozzle gear WA (2.9) using shaft gear (2.8).
 - Tighten the flush bolt (2.12) in the correct direction of rotation.
4. Insert the shaft (2.7) with nozzle gear WA (2.9) and collar bushings (2.4) from housing bottom (2.11) by tilting slightly.
5. Press the collar bushing (2.5) into the housing bottom (2.11).
6. Screw the 2x holding screws (2.14) into the housing bottom (2.11) and tighten.

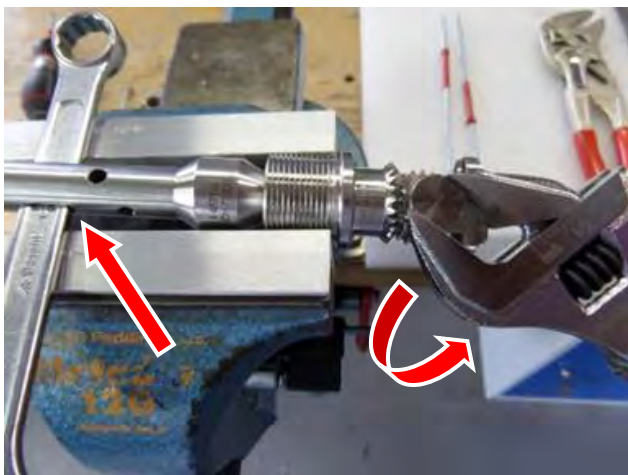

Tighten the Flush Bolt (2.12)



Tighten the Holding Screw (2.14)

7. Push the shaft gear (2.8) with bushing (2.2), bushing (2.3) onto the shaft (2.7).
8. Push the thrust washer (2.6) onto the shaft (2.7).
9. Screw the setting nut (2.13) onto the shaft (2.7).
10. Remove the head AG (2) from the vise.
11. Clamp the head AG (2) in the area of the shaft gear thread (2.8).
12. Secure setting nut (2.13) and shaft (2.7) with an open-end wrench to prevent them from turning.
13. Screw and tighten the nozzle carrier (3.1) onto the shaft gear (2.8).

14. **NOTE** When the shaft gear (2.8) is fixed, the housing bottom (2.11) must be able to move freely.

- Loosen setting nut (2.13) again by approx. $\frac{1}{4}$ to $\frac{1}{2}$ turn to prevent gear wheels from jamming.

15. Screw 2x set screws (2.15) into the setting nut (2.13) and tighten.

16. **NOTE** (only for head AG X70) The setting nut (2.13) is additionally secured against turning away from the shaft (2.7) by a dowel pin (2.16)!

- Drive the dowel pin (2.16) flush into the $\varnothing 3$ mm hole of the setting nut (2.13).



Tighten the Nozzle Carrier (3.1)

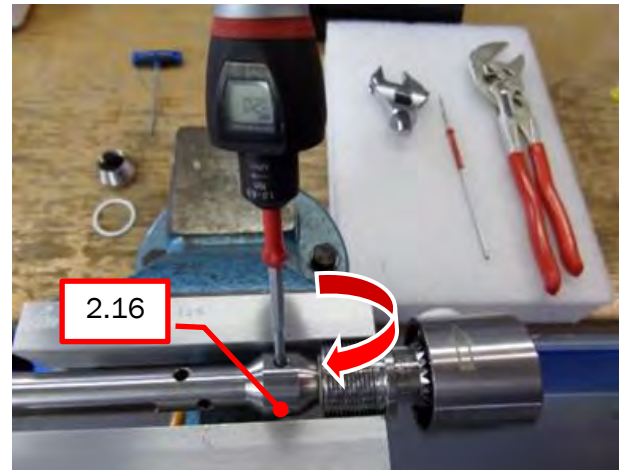

Tighten the Set Screw (2.15)

17. Screw the housing top (2.10) with housing bushing (2.1) onto the shaft gear (2.8).

18. Clamp the head AG (2) with the nozzle carrier (3.1) in the vise.

19. Screw and tighten 2x set screws (3.2) in the nozzle carrier (3.1).

20. **NOTE** Edge compression in the area of the wrench flats!

Damage to the nozzles.

- The wrench flat of nozzle (3.5) must protrude beyond the protective jaws.
- Place the gripping jaws of the adjustable wrench or pliers wrench against the wrench flats without play and over the entire surface.
- Screw and tighten nozzle (3.5) in the nozzle carrier (3.1).

Remark: Repeat the steps depending on the number of nozzles.



Tighten the Set Screw (3.2)



Tighten the Nozzle (3.5)

21. Remove complete head AG (2) from the vise.

22. **NOTE** To ensure that the cleaning head can rotate freely, observe the following:

- Perform a functional check of the head AG (2) rotary movements.
 - Hold the housing bottom (2.11) and turn the nozzle holder AG (3).

23. Before screwing the complete head AG (2) into the downpipe WA (1.1), push the fork of the setting nut (2.13) onto the shaft WA (1.2)

24. Screw the head AG (2) into the downpipe WA (1.1).



While screwing the head AG (2) and simultaneously holding the nozzle holder AG (3), a perceptible skipping of the magnetic coupling is normal when the actuator (4.1) is attached.

25. **NOTE** To ensure that the cleaning head can rotate freely, observe the following:

Cleaning head can jam!

- Tighten the housing top (2.10) hand-tight to the stop without using tools.
 - Set gap dimension of 0.1 to 0.2 mm between housing bushing (2.1) and housing top (2.10) with a distance/feeler gauge.

26. Screw 2x set screws (1.3) into the downpipe WA (1.1).

27. Secure head AG (2) by tightening 2x set screws (1.3).

7.4.4.3 Assembly – Head AG with JX80/70 Adapter



The adapter AG (2.10.1) is used to mount a head AG JX70 (2) to a basic device TANKO-JX80 (or JX75). If there is no shaft WA (1.2) or (5.2) in extended version for an adapter in the downpipe AG (1) or DPE AG (5), then the shaft WA (1.2) or (5.2) must be replaced or the head AG JX70 (2) must be used with a long setting nut (2.13).

1. Before screwing the complete head AG with adapter (2), slide the fork of the setting nut (2.13) onto the shaft WA (1.2).
2. Screw the head AG with adapter (2) into the downpipe WA (1.1) and tighten the adapter (2.10.1) at AF41 using an adjustable wrench or pliers wrench.
Remark: Tighten older versions without AF with a belt pipe wrench.



3. Screw 2x set screws (1.3) into the downpipe WA (1.1).
4. Secure head AG with adapter (2) by tightening 2x set screws (1.3).

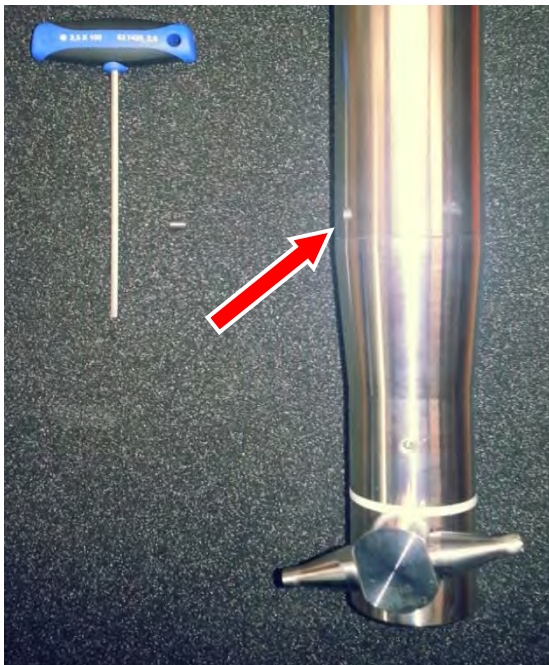

7.4.5 Notes on Cleaning

It is recommended for the device to be cleaned during maintenance.

Comply with the following safety instructions prior to cleaning.



WARNING



Hazard from corrosive or irritant cleaning agents!

Contact with the cleaning agent can generally NOT be ruled out during cleaning of the device.



There is a risk of death or severe physical injury.



- Adhere to the regulations and specifications in the safety data sheets for the cleaning agents (e.g. vapors or hazardous substances).
- Use personal protective equipment (e.g. protective gloves, safety shoes, safety goggles).
- Avoid excessively strong concentration of the cleaning agent.
- Only use clean and chlorine-free water as a diluting agent.
- Rinse the device with plenty of clean water after cleaning.
- Store cleaning agent in accordance with the applicable safety guidelines.

NOTE

Risk of damage to the device during cleaning!

The use of an incorrect cleaning agent or sharp objects can damage the device.

The functional safety and reliability of the device may be compromised.

- The cleaning agents must be approved for all materials on the device (e.g. gaskets, bushings).
- Do not use sharp objects (e.g. knives) or tools.

Cleaning in Assembled State:

As a basic rule, cleaning of the device parts that are located **inside the container** is NOT necessary. Self-cleaning takes place during the cleaning process.

Cleaning is carried out by simply rinsing the surfaces that come into contact with media (CIP cleaning).

Cleaning media:	3% nitric acid	max. +60 °C (+140 °F)
	3% caustic soda	max. +80 °C (+176 °F)

Before commencing cleaning work, the work steps of the switch-off procedure must be carried out (see [Section 7.2 Switch-off Procedure](#)).

When cleaning the parts of the device **outside the container**, make sure that dust and adhering materials (e.g. grease and oil residues) are removed.

On the electric motor, for example, the cooling fins and the grille of the fan must be cleaned so that no overheating can occur on the motor.

Cleaning in Disassembled State:

Prior to cleaning, the device must have been removed from the container by an **expert** and disassembled into its individual parts. The safety instructions in [Section 7.1 Safety Instructions for Maintenance](#) must be observed.

Cleaning of the device in a disassembled state can be carried out by **instructed persons**. After cleaning, the device must be assembled, checked and reinstalled in the container by an **expert** (see [Section 5.2 Installation](#)).

NOTE



Danger due to improper disposal!

Cleaning agents, consumables and lubricants must NOT be allowed to get into the groundwater, waterways or sewer system.

Improper disposal can cause environmental damage.

- *Dispose of any cleaning agents, lubricants and consumables (e.g. brushes and cloths) which have been used for cleaning in accordance with the local regulations and in accordance with the information in the manufacturer's safety data sheets.*
- *Dispose of packaging materials in an environmentally friendly manner and recycle them.*

7.5 Spare Parts and Customer Service

Spare Parts and Wear Parts



Subject to technical modifications in the interest of further development and improvement of the properties of the device. The Article No., dimensions or materials may differ from those of the supplied device.

NOTE



Removed spare/replacement parts should be recycled.

- For disposal information, refer to [Section 9.1 Disposal](#).

The following data is important when requesting spare parts and for all inquiries:

Device

- Type
- Serial number

Spare part

- Designation
- Article No.

Customer Service



For technical questions or spare part requests, you can contact the Customer Service department as follows:

Armaturenwerk Hötensleben GmbH

Schulstr. 5 - 6

D-39393 Hötensleben, Germany

Telephone: +49 39405 92-0

Fax: +49 39405 92-111

E-mail: info@awh.eu

Website: <http://www.awh.eu>

7.5.1 Spare Parts for JX Standard

Remark: The items marked "X" or "■" are included in the wear parts package and can be ordered. The items marked "■" are required for replacing wear parts [WP].

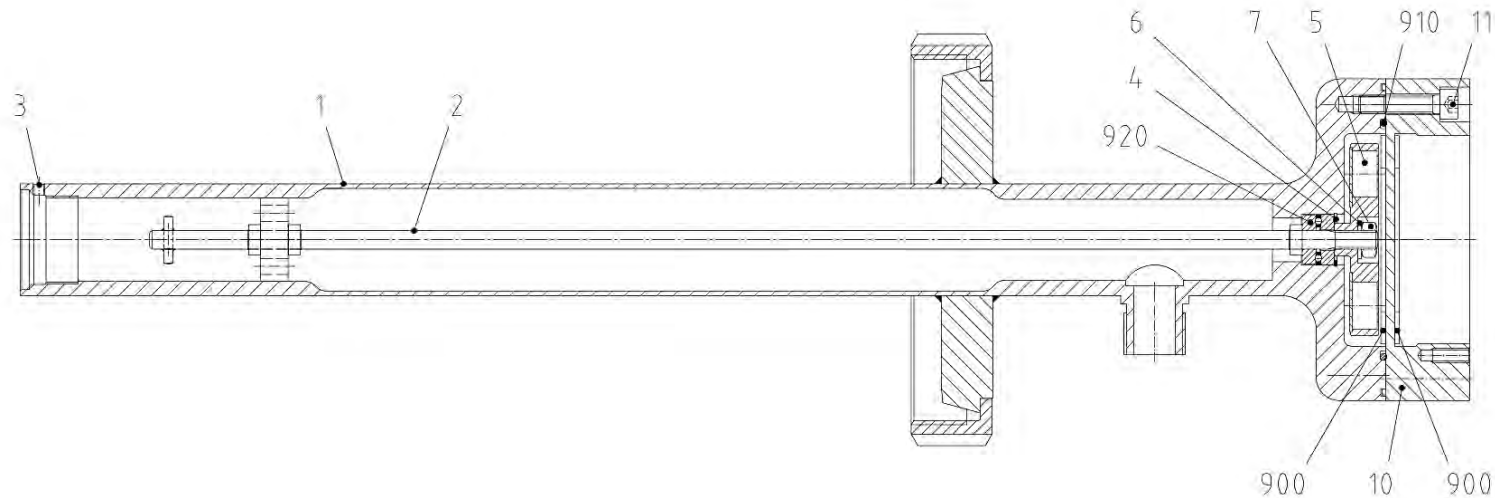

Figure 7.5-1: Downpipe AG with PC (JX75 and JX80)

Item	Qty.	Designation	Standard	Dimensions	Tightening torque [Nm]	Article No.			Material	[WP]
						TANKO-JX70	TANKO-JX75	TANKO-JX80		
1	1	Downpipe AG	AWH	According to order	----	66C2_00092_00 66C2_00093_00	66A3_00092_00 66A3_00093_00		----	--
1.1	1	Downpipe WA	AWH	According to order	----	66C2_00051052	66A3_00051052		1.4571	--
1.2	1	Shaft WA	AWH	According to order	----	66C0_00081050	66A0_00081050		1.4571 PTFE	--
1.3	2	Set screw	EN ISO 4026	M5 x 6	2.9 - 3.1	430182	430182 430174		1.4571	--
1.4	1	Locking ring for hole	DIN 472	J 22	----	450286	450286		1.4568	--
1.5	1	Shaft-side magnet carrier WA	AWH	Ø 58 - 21	----	66C0000032052	----		1.4571	--
				Ø 83 - 19	----	----	66A0000032052		1.4571	--

Item	Qty.	Designation	Standard	Dimensions	Tightening torque [Nm]	Article No.			Material	[WP]
						TANKO-JX70	TANKO-JX75	TANKO-JX80		
1.6	1	Washer	EN ISO 7089	Ø 6.4	----	450063	----	----	1.4571	--
				Ø 8.4	----	----	450060		1.4571	--
1.7	1	Hexagonal nut	EN ISO 4032	M6	5.0 - 5.4	570145	----	----	1.4571	--
				M8	13.0 - 14.4	----	570144		1.4571	--
1.8	---	----	----	----	----	----	----	----	----	--
1.90	2	Thrust washer	FDA	Ø 54 x 32 - 1.5	----	1105	----	----	Iglidur A500	--
				Ø 90 x 62 - 2.0	----	----	1089			--
1.91	1	O-ring	DIN ISO 3601-1	Ø 70.0 x 3.0	----	1060500007003	----	----	EPDM	--
				Ø 70.0 x 3.0	----	1060500007004	----	----	FKM-FEP	--
				Ø 98.0 x 3.0	----	----	1060500009803		EPDM	--
				Ø 98.02 x 3.53	----	----	10605241BT90S1		FKM-FEP	--
1.92	1	Axial bearing AG 1 (single row)	AWH	Ø 22 x 8 - 14.0	----	66A0000065004	66A0000065004		1.4571 PEEK	--
		Axial bearing AG 2 (double row)	AWH	Ø 22 x 8 - 14.6	----	66B0000065004	66B0000065004		1.4571 PEEK	--
1.10	1	Sealing flange	AWH	Ø 102.0 - 32.0	----	66C0000074052	----	----	1.4571	--
				Ø 139.0 - 36.5	----	----	66A0000074052		1.4571	--
1.11	8	Socket-head screw with hex socket	EN ISO 4762	M6 x 30	5.0 - 5.4	540035/540129	----	----	A2 / A4	--
				M8 x 35	13.0 - 14.4	----	540091/540171	540091/540171	A2 / A4	--

Table 7.5-1: Parts List for Downpipe AG (Standard)

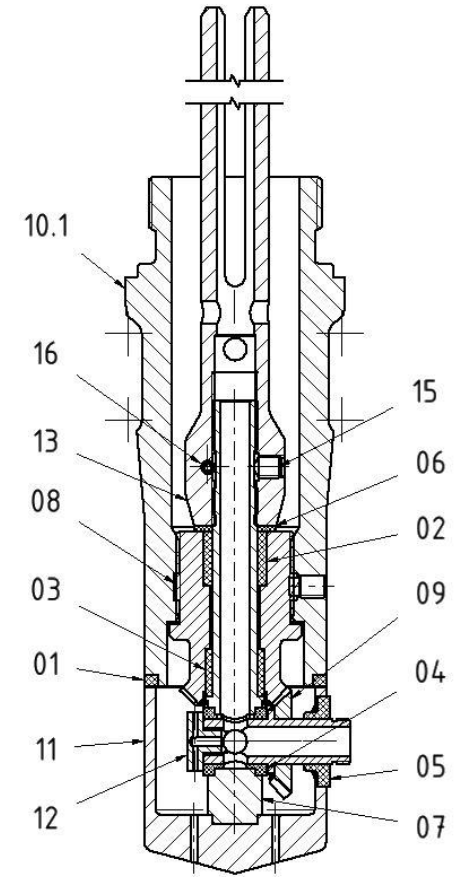
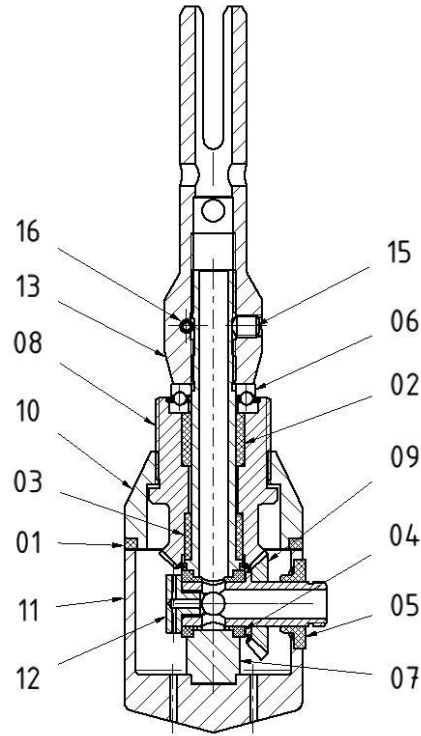
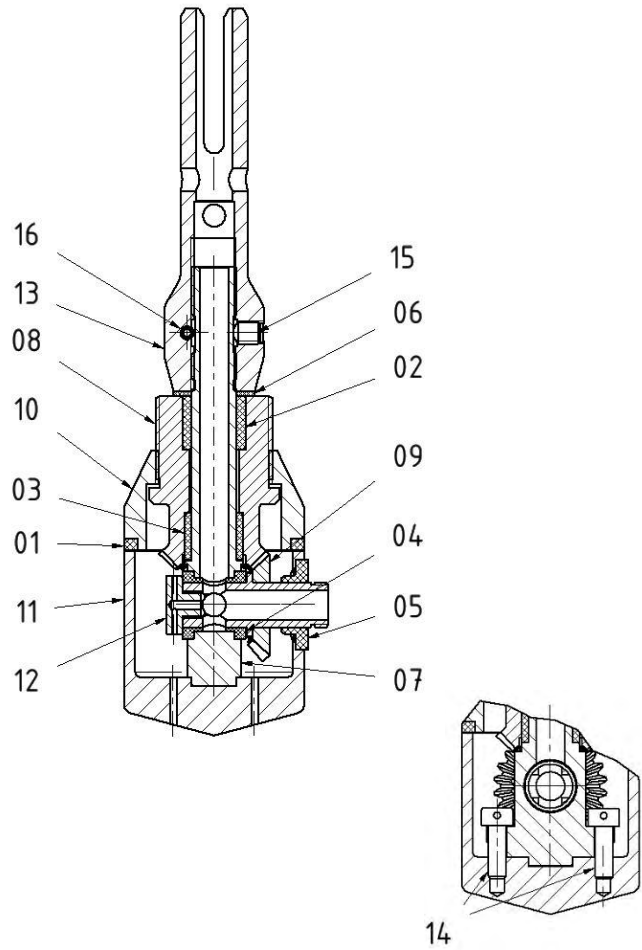

Figure 7.5-2: Head AG JX70 (with Thrust Washer)

Figure 7.5-3: Head AG JX70 (with Axial Bearing)

Figure 7.5-4: Head AG JX70 + Adapter

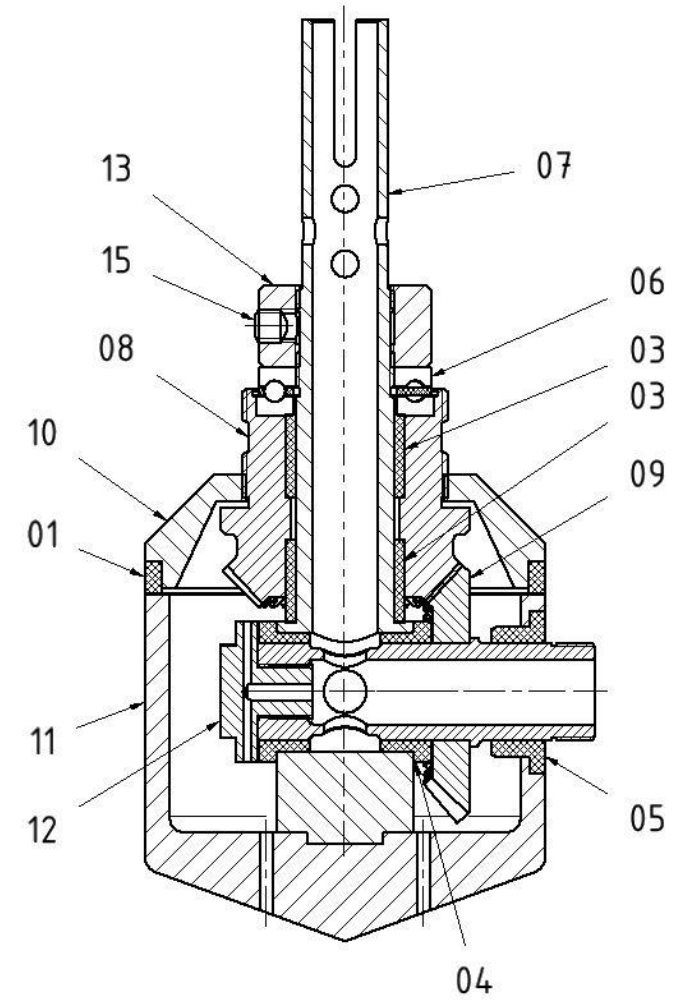
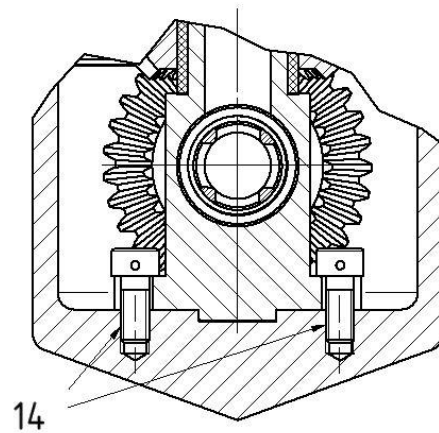
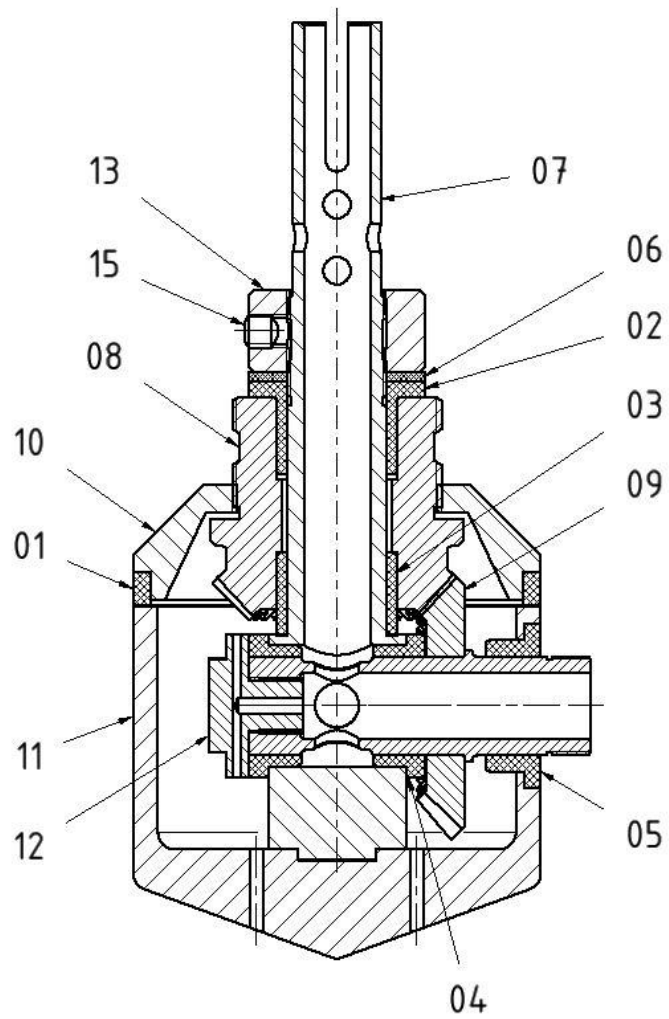

Figure 7.5-5: Head AG JX75 (with Thrust Washer)

Figure 7.5-6: Head AG JX75 (with Axial Bearing)

Item	Qty.	Designation	Standard	Dimensions	Tightening torque [Nm]	Article No.			Material	[WP]
						TANKO-JX70	TANKO-JX75	TANKO-JX80		
2	1	Head AG without nozzle holder (with thrust washer)	FDA Standard	Plain bearing	----	66C0F00029052	66D0F00029051	66A0F00029051	----	--
		Head AG without nozzle holder (with axial bearing AG)	AWH (optional)	Ball/plain bearing	----	66C0F00029053	66D0F00029053	66A0F00029053	66C0A00029052 (head AG TANKO-JX70 + adapter)	----
2.1	1	Housing bushing	AWH	Ø 40 x 34 - 2.5	----	66C00000010K0	----	----	PTFE	X
				Ø 74 x 67.5 - 6	----	----	66D00000010K0	----	PTFE	X
				Ø 80 x 73.5 - 6	----	----	66300000010K1	PTFE	X	
2.2	1	Bushing/Collar bushing	AWH	Ø 14 x 10 - 12 (optional)	----	66C00000070K0	----	----	PTFE	X
				Ø 32 x 18 - 17 (optional)	----	66C00000070N0	----	----	PEEK+PTFE	--
					----	66300000020K1	PTFE	X		
2.3	1	Bushing	AWH	Ø 13 x 10 - 10.5 (optional)	----	66C00000030K0	----	----	PTFE	X
				Ø 18 x 22 - 15.2 (optional)	----	66C00000030N0	----	----	PEEK+PTFE	--
					----	66300000030K1	PTFE	X		
2.4	2	Collar bushing	AWH	Ø 15 x 10 - 4.5 (optional)	----	66C00000040K0	----	----	PTFE	X
				Ø 26 x 18 - 9.5 (optional)	----	66C00000040N0	----	----	PEEK+PTFE	--
					----	66300000040K1	PTFE	X		
2.5	1	Collar bushing	AWH	Ø 20 x 10 - 5.8 (optional)	----	66C00000060K0	----	----	PTFE	X
				Ø 30 x 18 - 10.0 (optional)	----	66C00000060N0	----	----	PEEK+PTFE	--
					----	66300000050K1	PTFE	X		
2.6	1	Thrust washer	FDA	Ø 18 x 10 - 1.0	----	1101	----	----	iglidur A500	X
				Ø 32 x 18 - 1.5	----	----	1087			
		Axial bearing AG 3 (single row)	AWH (optional)	Ø 20 x 10 - 6.5	----	66C0000065004	----	----	1.4571	X
2.7	1	Shaft	AWH	M10 x 1.0	----	66C0000009051	----	----	1.4571	--
				M18 x 1.0	----	----	66D0000009050	6630000009051	1.4571	--

2.8	1	Shaft gear (for thrust washer)	AWH	z = 23	----	66C0000011050	----	----	1.4571	--
				z = 29	----	----	66D0000011050	6630000011051	1.4571	--
		Shaft gear (for axial bearing AG 3)	AWH (optional)	z = 23	----	66C0000011053	----	----	1.4571	--
				z = 29	----	----	66D0000011053	6630000011053	PEEK	--
2.9	1	Nozzle gear WA	AWH	z = 24	----	66C0000012051	----	----	1.4571	--
				z = 31	----	----	66D0000012050	6630000012051	1.4571	--
2.10	1	Housing top	AWH	M26 x 1.5	Hand tight without tools	66C0000013051	----	----	1.4571	--
				M38 x 1.5		----	66D0000013050	6630000013051	1.4571	--
2.10.1	1	Adapter AG JX80/70	AWH	M38 x 1.5		----	----	66B0000003050 (for head AG TANKO-JX70 + adapter)	1.4571 PTFE	--
2.11	1	Housing bottom	AWH	----	----	66C0000014051	66D0000014050	1.4571	--	
2.12	1	Flush bolt	AWH	M6 x 0.75 LH	4.6 - 4.8	66C0000015050	----	----	1.4571	--
				M10 x 1.0 LH	19 - 21	----	6630000015051	1.4571	--	
2.13	1	Setting nut short	AWH	M10 x 1.0	----	66C0000016051	----	----	1.4571	--
				M18 x 1.0	----	----	6630000016051	1.4571	--	
		Setting nut long	AWH	M10 x 1.0	----	66C0000016052	66C0000016052 (for head AG TANKO-JX70 + adapter)	1.4571	--	
2.14	2	Holding screw	AWH	M4 x 12	1.3 - 1.5	66C0000024051	----	----	1.4571	--
				M5 x 12	2.9 - 3.1	----	6630000024051	1.4571	--	
2.15	2	Set screw	EN ISO 4027	M5 x 6	2.0 - 2.2	430174	----	----	1.4571	■
				M6 x 6	2.6 - 2.8	----	430175	1.4571	■	
2.16	1	Heavy-duty dowel pin	----	∅ 3 - 16	----	440199	----	----	1.4568	■
---	---	Wear parts package	FDA Standard	Plain bearing	----	66C0F0E029051	66D0F0E029051	66A0F0E029051	----	X
			AWH (optional)	Ball/plain bearing	----	66C0F0E029053	66D0F0E029053	66A0F0E029053	----	X

Table 7.5-2: Parts List for Head AG without Nozzle Holder (Standard)

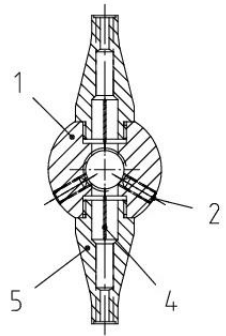

Nozzle holder AG 2-fold JX70

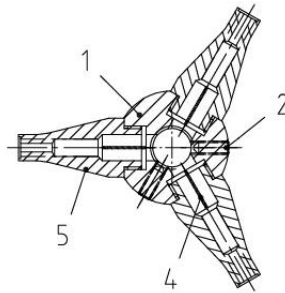

Nozzle holder AG 3-fold JX70

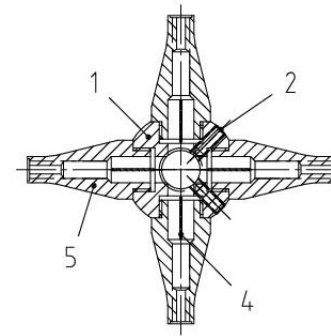

Nozzle holder AG 4-fold JX70

Figure 7.5-7: Nozzle Holder AG JX70

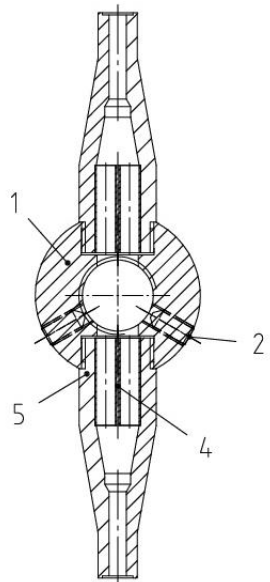

Nozzle holder AG 2-fold JX75

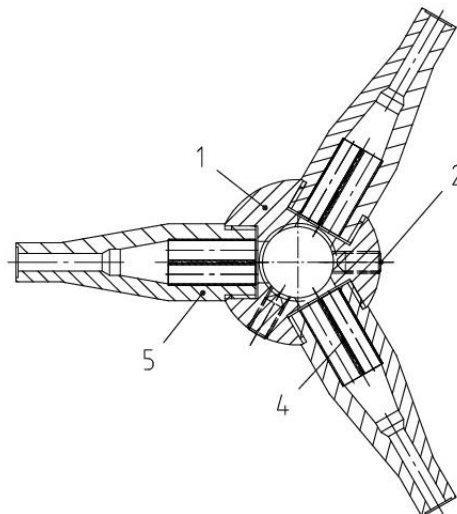

Nozzle holder AG 3-fold JX75

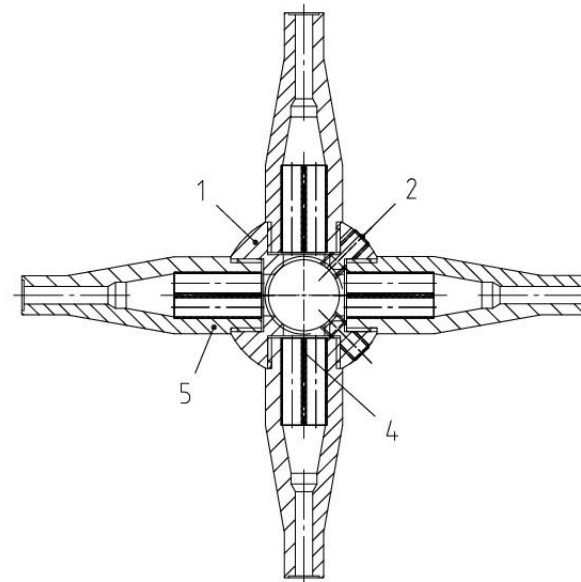

Nozzle holder AG 4-fold JX75

Figure 7.5-8: Nozzle Holder AG JX75

Item	Qty.	Designation	Standard	Dimensions	Tightening torque [Nm]	Article No.			Material	[WP]
						TANKO-JX70	TANKO-JX75	TANKO-JX80		
3	1	Nozzle holder AG	AWH	According to order	----	66C00__095052	66D00__095051	66A00__095051	----	--
3.1	1	Nozzle carrier	AWH	M10 x 1.0	12 - 14	66C00_0017051	----	----	1.4571	--
				M18 x 1.0	26 - 28	----	66D00_0017050	----	1.4571	--
				M18 x 1.0	26 - 28	----	----	66300_0017051	1.4571	--
3.2	2	Set screw	EN ISO 4027	M3 x 8	0.8 - 1.1	430046	----	----	1.4571	--
				M5 x 10	2.9 - 3.1	----	430047	----	1.4571	--
				M5 x 16	2.9 - 3.1	----	----	430048	1.4571	--
3.3	---	omitted	----	----	----	----	----	----	--	
3.4	ATO	Jet concentrator	AWH	According to order	----	66C0000020051	66D0000020050	6630000020050	1.4571	--
3.5	ATO	Nozzle	AWH	M10 x 1.0	26.0 - 28.0	66C000_021050	----	----	1.4571	--
				G 3/8"	33.0 - 35.0	----	66D000_021051	----	1.4571	--
				G 1/2"	44.0 - 46.0	----	----	66A000_021051	1.4571	--

Table 7.5-3: Parts List for Nozzle Holder AG (Standard)

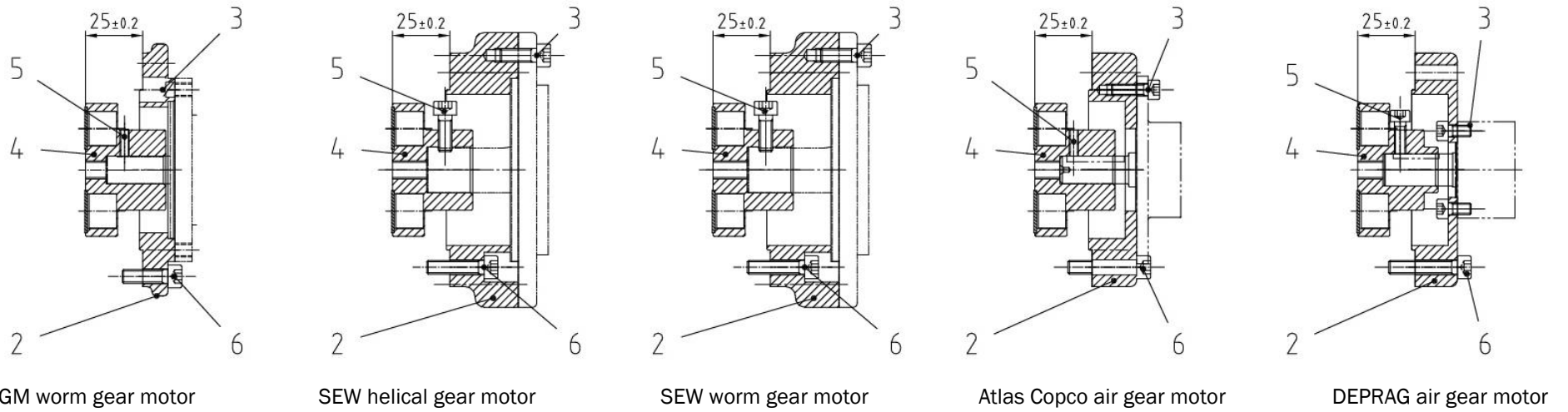

Figure 7.5-9: Motor Connection AG JX70

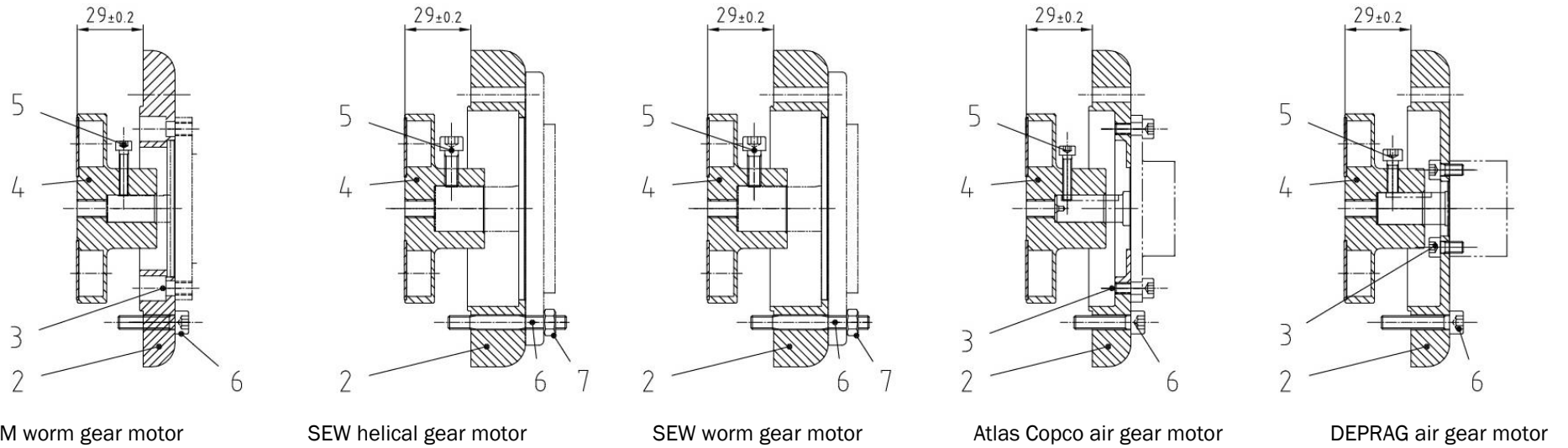

Figure 7.5-10: Motor Connection AG JX80 and JX75

Item	Qty.	Designation	Standard	Dimensions	Tightening torque [Nm]	Article No.				
						TANKO-JX70				
4	1	Motor connection AG	AWH	According to order	----	RGM	SEW	Atlas Copco	DEPRAG	
						66CVBGMR00000	66CVBGMS00000	66CVBGMA00000	66CVBGMD00000	
4.1	1	Actuator/motor	----	According to order	----	Worm gear motor	Worm gear motor Helical gear motor	Air gear motor	Air gear motor	
4.2	1	Motor flange	AWH (1.4571)	Ø 110 / 70	----	66C0000071350	----	----	----	
				Ø 120 / 100	----	----	66C0000071250	----	----	
				Ø 102 / 70	----	----	----	66C0000071550	----	----
				Ø 102 / 34	----	----	----	----	66C0000071650	----
4.3	2	Socket-head screw with hex socket	EN ISO 4762 (A2)	M5 x 14	2.9 - 3.1	----	----	540101	----	
	4			M5 x 10	2.9 - 3.1	----	----	----	540083	
	M6 x 12			5.0 - 5.4	540030	----	----	----		
	M6 x 16			5.0 - 5.4	----	540031	----	----		
4.4	1	Motor-side magnet carrier WA	AWH (1.4571)	----	----	66C0000035352	66C0000035252	66C0000035552	66C0000035652	
4.5	1	Set screw	EN ISO 4029 (A2)	M4 x 12	1.3 - 1.5	430164	----	430164	----	
		Socket-head screw with hex socket	EN ISO 4762 (A2)	M5 x 16	2.9 - 3.1	----	----	----	540114	
				M6 x 16	5.0 - 5.4	----	540031	----	----	
4.6	3	Socket-head screw with hex socket	EN ISO 4762 (A2)	M6 x 20	5.0 - 5.4	540032	----	----	----	
	4			M6 x 25	5.0 - 5.4	----	540034	----	----	
	M6 x 30			5.0 - 5.4	----	----	540035	540035		

Table 7.5-4: Parts List for Motor Connection AG JX70 (Standard)

Item	Qty.	Designation	Standard	Dimensions	Tightening torque [Nm]	Article No.				
						TANKO-JX75 / TANKO-JX80				
						RGM	SEW	Atlas Copco	DEPRAG	
4	1	Motor connection AG	AWH	According to order	----	66AVBGMR00000	66AVBGMS00000	66AVBGMA00000	66AVBGMD00000	
4.1	1	Actuator/motor	----	According to order	----	Worm gear motor	Worm gear motor Helical gear motor	Air gear motor	Air gear motor	
4.2	1	Motor flange	AWH (1.4571)	∅ 139 / 70	----	66A0000071350	----	----	----	
				∅ 139 / 100	----	----	66A0000071250	----	----	
				∅ 139 / 70	----	----	----	66A0000071550	----	----
				∅ 139 / 34	----	----	----	----	66A0000071650	----
4.3	2	Socket-head screw with hex socket	EN ISO 4762 (A2)	M5 x 14	2.9 - 3.1	----	----	540101	----	
	4			M5 x 10	2.9 - 3.1	----	----	----	540083	
	M6 x 12			5.0 - 5.4	540030	----	----			
4.4	1	Motor-side magnet carrier WA	AWH (1.4571)	----	----	66A0000035352	66A0000035252	66A0000035552	66A0000035652	
4.5	1	Socket-head screw with hex socket	EN ISO 4762 (A2)	M4 x 20	1.3 - 1.5	540022	----	540022	----	
				M5 x 16	2.9 - 3.1	----	----	----	540114	
				M6 x 16	5.0 - 5.4	----	540031	----	----	
4.6	3	Socket-head screw with hex socket	EN ISO 4762 (A2)	M6 x 25	5.0 - 5.4	540034	----	----	----	
	4			M6 x 30	5.0 - 5.4	----	----	540035	540035	
	Stud screw	DIN 939 (A2)	M6 x 40	5.0 - 5.4	----	490103	----	----		
4.7	4	Hexagonal nut	EN ISO 4032 (A2)	M6	5.0 - 5.4	----	570007	----	----	

Table 7.5-5: Parts List for Motor Connection AG JX75 and JX80 (Standard)

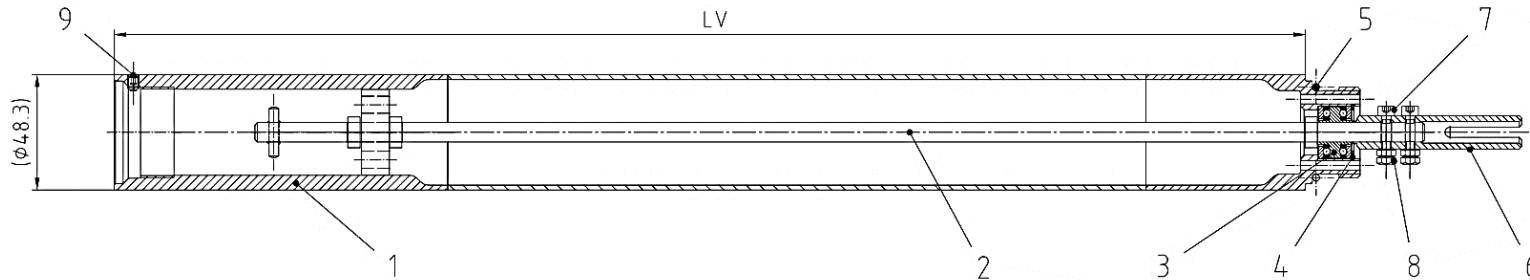

Figure 7.5-11: Downpipe Extension [DPE] AG

Item	Qty.	Designation	Standard	Dimensions	Tightening torque [Nm]	Article No.		Material	[WP]
						TANKO-JX75	TANKO-JX80		
5	1	DPE AG	AWH	LEXT=1000mm LEXT=0750mm LEXT=0500mm	----	66B010A400051 66B040A400051 66B020A400051	----	---	
5.1	1	Pipe WA for DPE	AWH	LEXT=1000mm LEXT=0750mm LEXT=0500mm	----	66B0100001051 66B0400001051 66B0200001051	1.4571	---	
5.2	1	Shaft WA for DPE	AWH	LEXT=1000mm LEXT=0750mm LEXT=0500mm	----	66B0100005051 66B0400005051 66B0200005051	1.4571 PTFE	---	
5.3	1	Axial bearing AG 2	AWH	Ø 22 x 8 - 14.6	----	66B0000065004	1.4571 PEEK	---	
5.4	1	Locking ring	DIN 472	J 22	----	450286	1.4568	---	
5.5	1	O-ring	DIN ISO 3601-1 DN 32	Ø 33.0 x 3.0	----	1060500003254	EPDM	---	
5.6	1	Coupling piece for DPE	AWH		----	66B0000006051	1.4571	---	
5.7	2	Socket-head screw with hex socket	EN ISO 4762	M4 x 20	1.3 - 1.5	540147	1.4571	---	
5.8	4	Hexagonal nut	EN ISO 4032	M5	2.9 - 3.1	570142	1.4571	---	
5.9	2	Set screw	EN ISO 4029	M5 x 6	2.9 - 3.1	430174	1.4571	---	

Table 7.5-6: Parts List for DPE AG JX (Standard)

8 Faults

8.1 Safety Instructions for Troubleshooting

Before rectifying a fault, the following safety instructions must always be adhered to:

DANGER



Danger to life due to live components!

Activated electrical components are live with dangerous electrical voltage and may perform uncontrolled movements. An electric shock may occur from coming into contact with these components.

There is a risk of death or severe physical injury.

- Allow only **qualified electricians** to perform work on the electrical system.
- Before starting work, observe the **work steps of the switch-off procedure** (see [Section 7.2 Switch-off Procedure](#)).
- Cover adjacent live parts to prevent contact.
- Beware of the hazards caused by electrical current (e.g. warnings).

WARNING



Risk of chemical burns and heat burns when opening the container!

The supply line is pressurized. The person may be struck by cleaning jets or come into contact with residual fluid from the supply line and device. There may also be hot vapors in the container.



There is a risk of death or severe physical injury.



- **Do NOT open the container** during the cleaning process.
- Before starting work, observe the **work steps of the switch-off procedure** (see [Section 7.2 Switch-off Procedure](#)).
- Before opening the container, observe the **cooling and draining time**.
- Use personal protective equipment (e.g. protective gloves, safety shoes, safety goggles).



**WARNING****Hazardous situations caused by performing work on the device incorrectly!**

There is a risk of death or severe physical injury.

- Repairs and troubleshooting work must be performed only by qualified experts who have knowledge of the German Technical Rules for Operational Safety.
- Before starting work, observe the **work steps of the switch-off procedure** (see [Section 7.2 Switch-off Procedure](#)).
- Before rectifying any fault, observe the safety instructions in [Chapter 7 Maintenance](#).
- In case of any uncertainty or doubt, contact AWH.

**WARNING****Danger caused by ejection of the cleaning medium!**

If the cleaning medium is unexpectedly ejected after a system failure (e.g. pressure drop due to interruption of the pressure supply) there is a risk of accident.

There is a risk of death or severe physical injury.

- Do NOT remove the device if the cleaning medium has failed.
- Always follow the work steps of the **switch-off procedure** (see [Section 7.2 Switch-off Procedure](#)).

**WARNING****Danger of crushing being drawn into the equipment due to inadvertent starting-up of the actuator!**

Danger could arise from a sudden, unforeseeable return of energy supply (e.g. unauthorized switching back on).

There is a risk of death or severe physical injury.

- Switch off the energy supply (e.g. electricity or compressed air) before all maintenance, cleaning or repair work.
- Before starting work, observe the **work steps of the switch-off procedure** (see [Section 7.2 Switch-off Procedure](#)).

8.2 Faults and Remedial Action

Fault	Cause	Remedy
The device does not work or the motor does not start.	– Motor defective.	– Replace motor.
	Electric motor	
	– Electric power is not being supplied.	– Check connections/fuses, switch on main switch, insert mains plug into mains socket.
	Air motor	
	– Compressed air is not being supplied.	– Open the shut-off valve for the compressed air.
Cleaning head and/or nozzle carrier not rotating or rotating unevenly.	– Compressed air filter clogged.	– Clean compressed air filter.
	– Pressure of the cleaning medium too high.	– Reduce the pressure.
	– Excessive friction due to wear on the bushings and/or bearings	– Check the bushings and/or bearings for wear, clean or replace them.
	– Magnetic carrier loose.	– Screw on magnetic carrier securely.
	– Cleaning head contaminated by deposits or foreign bodies.	– Clean the cleaning head and remove foreign bodies.
	– Teeth of spur gears damaged and jammed.	– Replace the spur gears.
	– The cleaning head collides with installed components.	– Eradicate the interfering contours.
	– Nozzles are blocked mechanically by interfering contours.	– Check the position in the container.
Effectiveness of cleaning is not sufficient.	– Nozzle jet too close to surrounding components. Due to high media pressure (recoil).	– Increase the distance to surrounding components.
	– Nozzles soiled or blocked.	– Clean or replace the nozzles.
	– Pressure of the cleaning medium too low.	– Increase the pressure (adhere to the max. permitted pressure).
	– Volume flow rate too low.	– Increase the volume flow rate.
	– Filter blocked.	– Clean or replace the filter.

Fault	Cause	Remedy
Jet pattern not ideal.	- No jet concentrators in the nozzles.	- Retrofit jet concentrators.
	- Nozzles soiled.	- Clean the nozzles.
	- Nozzles damaged.	- Replace the nozzles.
Noise at the magnetic coupling.	- Nozzles are blocked mechanically by interfering contours.	- Check the position in the container.
	- High media pressure (recoil), nozzle jet too close to surrounding components.	- Increase the distance to surrounding components.
	- Magnetic coupling loose.	- Screw on magnetic carrier securely.
Process or media connection leaking.	- Gasket faulty.	- Replace the gasket.
	- Connections have come loose.	- Check the tightening torques of the screw connections.
Volume flow rate too high.	- Increased leakage due to heavily worn bushings or bearings.	- Replace the bushings or bearings.

Table 8.2-1: Operating Faults – Cause and Remedy

If the specified measures are NOT successful, please contact AWH.



In the event of return shipment (e.g. repair/servicing/return), a hazardous substance declaration must be enclosed with the device in accordance with the German Ordinance on Hazardous Substances (GefStoffV).

Request the form for the hazardous substance declaration from AWH.

8.3 What to do in Case of an Emergency

If a hazardous situation occurs, or if you need to avert a potential danger, quickly set the device to a safe state.

The type of EMERGENCY STOP circuit used for the device is to be determined depending on the hazards and operating conditions and is the sole responsibility of the operating company.

It is for this reason that AWH can offer the operating company, **solely as a precautionary measure, a few points of reference and notes** to be observed and to be integrated into the operating company's hazard and risk assessments.

- The work steps for switching off the device listed in [Section 7.2 Switch-off Procedure](#) must be adhered to.
- The EMERGENCY STOP circuit must be designed in such a way that the machine or system operator can actuate it immediately in the event of an emergency.
- Switching off with the "EMERGENCY STOP" in case of emergency is intended to disconnect the entire machine from the supply voltage without delay in order to eradicate the risks caused by electrical voltage immediately.
- Switching off with the "EMERGENCY STOP" in case of emergency is intended to prevent risks which cause hazardous movements as soon as possible.
- The EMERGENCY STOP must have priority over all other functions and actuations in all operating modes.
- Resetting must not cause the plant/machine to start up again.



Source:

- EN 60204-1 / VDE 0113-1 "Safety of machinery – Electrical equipment of machines – Part 1: General requirements"
- EN ISO 13850: "Safety of machinery - Emergency stop function - Principles for design"

In Case of an Emergency:

Trigger the EMERGENCY STOP function on the higher-level plant/machine.

- Actuate the **EMERGENCY STOP** switch
- Interrupt the actuator energy supply
 - Interrupt electricity supply (e.g. electrical actuator)
 - Switch off higher-level main switch
 - Pull out power plug
 - Close the compressed air shut-off valve (e.g. pneumatic actuator)
- Interrupt the supply of cleaning medium (actuator energy)
 - Close the shut-off valve

9 Decommissioning

Once the device has reached the end of its service life, it must be removed from the container, dismantled and disposed of in an environmentally friendly manner. Disposal must be performed in accordance with the respective valid local, national and international regulations.

WARNING



Danger due to improper decommissioning/disposal!

There is a risk of intoxication or chemical burns when using harmful or toxic media, or media which is hazardous in any other way.



There is a risk of death or severe physical injury.

- Only an expert should perform the work.
- Before starting work, observe the **work steps of the switch-off procedure** (see [Section 7.2 Switch-off Procedure](#)).
- Use protective work clothing, protective gloves and safety goggles when carrying out the work.
- In case of any uncertainty or doubt, contact AWH.



Removal

Only **experts** are permitted to perform the removal from the container and the disassembly of the device for disposal. [Section 7.3 Removal](#) contains information on the removal of the devices and its interfaces. The safety instructions in [Section 7.1 Safety Instructions for Maintenance](#) must be observed.

9.1 Disposal

CAUTION



Danger from harmful fluids which are a health hazard!

During disposal, there is a risk of injury from contact with harmful fluids.

There is a risk of minor or moderate injuries.



- Use personal protective equipment (e.g. protective gloves, safety shoes, safety goggles).

NOTE



The cleaning device is made predominantly of stainless steel. Stainless steel is a valuable raw material and can easily be recycled.

After removal, the entire device must be properly:

- Cleaned (see [Section 7.4.5 Notes on Cleaning](#)) and
- Disassembled into its assembly groups and individual parts (see [Section 7.4.3 Disassembling the Device](#))

Unless other arrangements have been made for return or disposal, disassembled components should be recycled:

- Scrap any parts made of metal
- Recycle any parts made of plastic
- other parts to be sorted according to material properties and disposed of

If necessary, contact a specialist company to arrange for disposal.

Comply with locally applicable health, safety, disposal and environmental protection regulations.

NOTE***Danger due to improper disposal!***

Cleaning agents, consumables and lubricants must NOT be allowed to get into the groundwater, waterways or sewer system.

Improper disposal can cause environmental damage.

- *Dispose of any cleaning agents, lubricants and consumables (e.g. brushes and cloths) which have been used for cleaning in accordance with the local regulations and in accordance with the information in the manufacturer's safety data sheets.*
- *Dispose of packaging materials in an environmentally friendly manner and recycle them.*

Index

A		Qualified electrician..... 107
Abbreviations	V	Qualified Electrician..... 38, 61
Assembling the Device	83	Explanation of Signal Words
		Explanation of the Warnings
		2
C		F
Cleaning Media	8, 9, 30	Faults..... 6, 107
Cleaning Times		Faults and Remedial Action
Cleaning Times	27	Filter..... 31, 33, 39, 42, 73, 109
Cleaning Times JX70	27	Flow Meter..... 33, 39
Cleaning Times JX75/JX80	27	Functional Check
Commissioning	52	Trial Run with the Device..... 55, 61, 71
Connection of the Actuator	49	G
Connection to Disposal System	41	General Function Description
Connection to the Power Supply.....	39	24
Connections	13	I
Construction.....	17	Installation..... 37, 41
Construction and Function.....	17	Installation Length
Container		Installation Opening
Container in the Context of these Instructions		Container..... 28, 45, 47, 48, 66, 67
.....	7	Installation Dimensions..... 29
Control System.....	37, 70	Mobile Device..... 28, 48
Customer Service.....	94	Removal..... 67
		Stationary Device..... 28, 47, 67, 68
D		Installation Position
Decommissioning	112	Installing the Device
Device Interfaces	63	Mobile Device..... 48
Cleaning Head.....	43	Stationary Device..... 47
Electrical Connection.....	49, 50	Intended Use
Media Connection [MC].....	18, 28, 43, 66	7
Pneumatic Connection	49, 51	Interfaces
Process Connection [PC]...	18, 21, 28, 43, 46	43
Rinsing connection [RC]	66	Internal Fittings
Rinsing Connection [RC].....	18, 43, 46	Movable Internal Fittings..... 25, 48, 68
Device with DPE.....	24	M
Direction of Rotation	50	Maintenance
Direction of Rotation Arrow	47, 50, 68	61, 68
Disassembling the Device	76	Assembly – Head AG
Disposal.....	112	Assembly – Head AG with Adapter
Duties of the Operating Company	11	Assembly – Magnetic Coupling..... 83
		Disassembly – Head AG
E		Disassembly – Head AG with Adapter
Emergency.....	111	Disassembly – Magnetic Coupling..... 76
Equipment.....	33, 70	Maintenance Points..... 72
Expert		Maintenance Intervals..... 71
Expert	6, 14, 38, 53, 62, 93, 112	Marking..... 16
Instructed Person	14, 93	Means of Presentation
		1, 3

N			
Noise Level			
Noise Level of the Device	28, 54		
Noise Level of the Plant	54		
Non-Intended Use.....	10		
Notes on Cleaning.....	92		
O			
Operation	57		
Original Spare Parts	7, 11, 61		
P			
Packaging.....	34		
Personal Protective Equipment	15		
Pictograms and Symbols.....	4		
Pressure			
Operating Pressure.....	27		
Product Names and Trademarks	5		
R			
Range	27		
Cleaning	27		
Wetting.....	27		
Related Documents.....	5		
Removal	65, 112		
Removing the Device	66		
Mobile Device	68		
Stationary Device	67		
Requirements for Personnel.....	14		
S			
Safety	6		
Safety Instructions for Commissioning	52		
Safety Instructions for Installation	37		
Safety Instructions for Maintenance.....	61		
Safety Instructions for Troubleshooting....	107		
		Safety Devices	7
		Scope of Delivery	33
		Shut-off fitting	57
		Shut-off Fitting	10, 25, 33, 39
		Spare Parts and Customer Service	94
		Spare Parts and Wear Parts	
		Spare Parts	94
		Spare Parts, Replacement Parts and	
		Accessories	11
		Special Designs	18
		Storage	35
		Switch-off Procedure	63
		Switch-on Procedure	56
		T	
		Technical Data	27
		Temperature	
		Ambient Temperature	10, 27, 28
		Operating Temperature	27
		Tools and Tightening Torques.....	74
		Transportation	35
		Transportation and Storage	33
		Type Designation	16
		Type Plate.....	7, 16
		Type Plate of the Actuator	40, 49, 118
		U	
		Units of Measure	VII
		W	
		Warranty and Liability.....	5
		Water hammer	57
		What to do in Case of an Emergency	111
		Work Steps	
		Switch-off Procedure	38, 58, 59, 61, 62, 63, 65, 107, 108, 111, 112
		Switch-on Procedure	56

Annexes

Annex 1: Declaration (Translation)	117
Annex 2: Overview of Actuators	118
Annex 3: Corrosion Resistance of Steels (Excerpts from Data Sheets)	121

Annex 1: Declaration (Translation)

Armaturenwerk Hötensleben GmbH

Schulstr. 5 – 6
39393 Hötensleben

Telephone: +49 39405 92-0
Fax: +49 39405 92-111E
Email: info@awh.eu
Internet: <http://www.awh.eu>

Declaration of incorporation in accordance with the EC Machinery Directive 2006/42/EC, Annex II B

We hereby declare that the container cleaning device

Designation: Jet cleaner
Type/series: TANKO-JX70; TANKO-JX75; TANKO-JX80; TANKO-JX80/70
Year of manufacture: See type plate on the device
Serial number: See type plate on the device

complies with the following basic health and safety requirements of Directive 2006/42/EC, Annex I:
1.1.2 – 1.1.7, 1.3, 1.5.2 – 1.5.9, 1.5.15, 1.5.16, 1.6, 1.7.1 – 1.7.3, 1.7.4, 1.7.4.1, 1.7.4.2, 1.7.4.3.

The specific technical documents have been compiled in accordance with Directive 2006/42/EC, Annex VII, Part B.

The supplied version of the device corresponds to the following directives and standards:

Directive/standard	Title	Version	Remarks
2006/42/EC	EC Machinery Directive	2006	
DIN EN ISO 12100	Safety of machinery - General principles for design - Risk assessment and risk reduction	2011-03	Harmonized standard
	DIN EN ISO 12100 Corrigendum 1	2013-08	
DIN EN ISO 4413	Hydraulic fluid power - General rules and safety requirements for systems and their components	2011-04	Harmonized standard
DIN EN ISO 4414	Pneumatic fluid power - General rules and safety requirements for systems and their components	2011-04	Harmonized standard

If any modifications are made to the device without our consent, this declaration shall lose its validity.

Start-up is prohibited until it is determined that the overall system fulfills the applicable provisions of the directives to be applied.

Hötensleben, 7. June 2021

Thomas Erhorn (CEO) ^{a) b)}

^{a)} Authorized representative to issue this declaration on behalf of the manufacturer

^{b)} Authorized representative to compile the technical documentation with identical address of the manufacturer

Annex 2: Overview of Actuators



WARNING



Danger due to improper connection to the power supply!

The technical data, the connected loads for the power supply (electric or pneumatic) depend on the type of actuator mounted.

Failure to observe the instructions for the actuator can result in various sources of danger.

There is a risk of death or severe physical injury.

- Observe the type plate of the actuator.
- Compare the information on the type plate of the actuator with the associated documentation from the actuator manufacturer.
- Consistently observe the connection conditions of the actuator manufacturer.

The following actuators can be used:

Examples - Electric Gear Motors (Manufacturer RGM)

Designation	Type	Weight
Worm gear motor	SN 4 F	≈ 4.1 - 4.6 kg
Worm gear motor (FC operation)	SN 4 F-FU	≈ 5.4 kg

Device	TANKO-JX70	TANKO-JX75	TANKO-JX80
Actuator (standard):	Gear motor RGM	Gear motor RGM	Gear motor RGM
- Type	SN 4 F	SN 4 F	SN 4 F
- Power	45W	90W	90W
- Voltage; frequency	230 / 400V 50Hz	230 / 400V 50Hz	230 / 400V 50Hz
- Current	0.31 / 0.18A	0.74 / 0.43A	0.74 / 0.43A
- Protection class	IP 54	IP 54	IP 54
- Weight	≈ 4.1 kg	≈ 4.6 kg	≈ 4.6 kg

For the standard worm gear motor RGM type SN 4 F, any spatial position can be chosen, and operation with an external frequency converter is possible to a limited extent.

Examples - Electric Gear Motors (Manufacturer SEW-EURODRIVE)

Gear unit type	Gear unit series	Weight (with motor)
Worm gear motor	SF37	≈ 12 – 24 kg
Spiroplan gear motor	WF30	≈ 9 – 13 kg
Helical gear motor	RF17	≈ 7 – 9 kg
	RF37	≈ 17 kg
Worm gear motor (FC operation)	SF37	≈ 23 kg
Helical gear motor (FC operation)	RF27	≈ 21 kg
	RF37	≈ 25 kg

Remark:

Depending on the version of the electric motor, FC operation is optionally possible.

NOTE



Damage to the gear motor due to incorrect spatial position!

There are different design-dependent spatial positions for the gear units. Depending on the spatial position of the gear motor, a sufficient oil level must be ensured in the gear unit. All teeth, rolling bearings, etc. must be immersed in oil by rotations and completely lubricated. Therefore, the gear units may only be installed/mounted in specified spatial positions.

Failure to observe this may result in gear oil escaping. Damage to the gear motor and its surroundings may result.

- Specify the spatial position of the gear motor (types M1...M6) when ordering.
- If the installation position of the gear motor differs from that specified in the order or if it is used in a different installation position, observe the notes in the gear unit manufacturer's operating instructions.
- Check the position of the oil level checking screw, the oil drain plug and the exhaust valve.
- Observe design-dependent oil filling appropriate for the spatial location.

Helical gear motors R...

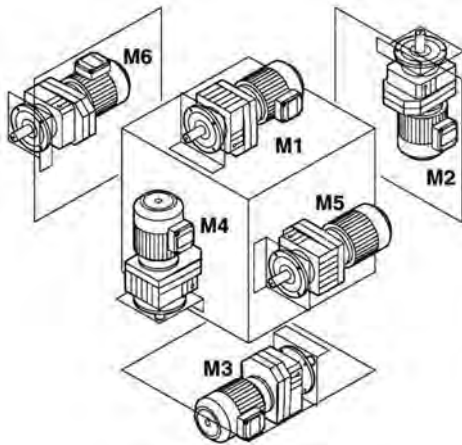

Spiroplan gear motor W...
Worm gear motor S...

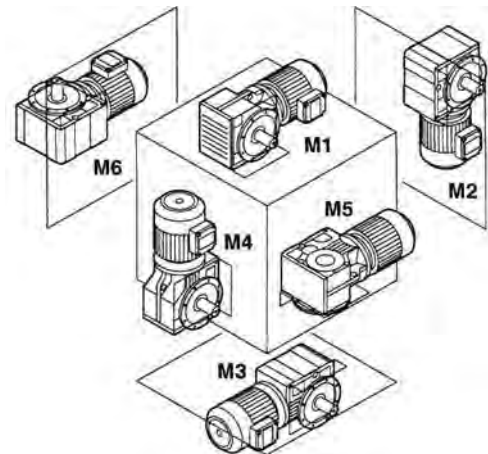

Figure 9.1-1: Spatial Positions of Gear Motors (Example SEW-EURODRIVE)

The performance data in the following table are excerpts from the respective manufacturer's documentation and refer to 6.3 bar (91.4 psig) operating pressure for Atlas Copco air motors and 6.0 bar (87 psig) operating pressure for DEPRAG air motors.

All external parts of air motors are made of high quality stainless steel.

Examples - Air Gear Motors

Manufacturer	Atlas Copco		DEPRAG
Designation/Type	LZB 34RL LR10-11	LZB 34RL LR44-11	67X-2931
Rated power [W]	230	230	300
Idle speed [min ⁻¹]	10	44	50
Air consumption at idle speed [l/s] [m ³ /min]	9.90 0.59	9.90 0.59	7.90 0.47
Weight [kg]	2	1.75	1.30
Lamella type	Oil-free		Oil-free
Material (external)	Stainless steel		Stainless steel
Hose width [mm]	8		10

Table 9.1-1: Overview of Air Motors

Annex 3: Corrosion Resistance of Steels (Excerpts from Data Sheets)

Material no. 1.4016 (AISI 430)

Stainless ferritic chrome steel

Although the corrosion resistance of 1.4016 is low compared to austenitic stainless grades, its ferritic microstructure makes it resistant to the effects of stress corrosion cracking, a form of corrosion to which most conventional austenitic stainless steels are highly sensitive. Despite this excellent property, the use of 1.4016 is limited by its poor welding properties. 1.4016 is a ferritic steel grade whose corrosion resistance is higher than that of 1.4003 or any other 13% chrome steel due to its higher chrome content. Good corrosion resistance is shown in media with low aggressiveness and with low chlorine ion concentration, such as domestic environment, natural water and solvents.

It should be noted that 1.4016 is not resistant to seawater. 1.4016 is resistant to intergranular corrosion as supplied, but not after welding or processing at elevated temperatures.

Material no. 1.4104 (AISI 430F)

Stainless ferritic chrome steel with added sulfur

Compared with the ferritic steel 1.4016, the machinability of 1.4104 is improved by the deliberate addition of sulfur. However, despite the same chrome content, corrosion resistance is reduced by the sulfur compared to M1.4016. This is particularly noticeable in media containing chlorine. Due to the carbon content, an improvement of the mechanical properties is possible by quenching and tempering. Although 1.4104 is in the order of 17% chrome steels, the addition of sulfur compromises corrosion resistance, especially in media that cause pitting or crevice corrosion.

Material no. 1.4301 (AISI 304)

Stainless austenitic chrome-nickel steel

1.4301 is the standard for austenitic chrome-nickel steels. It is used in numerous areas because of its high corrosion resistance and ease of processing, as well as its attractive appearance in a high-gloss polished, ground or brushed condition. Because 1.4301 is not resistant to intergranular corrosion when welded, if large parts have to be welded and subsequent solution annealing is not possible, 1.4307 should be used.

The moderate carbon content of 1.4301 means that this grade tends to be sensitive. The formation of chromium carbides and the associated areas of depleted chrome around these depositions make this steel susceptible to intergranular corrosion. Although there is no risk of intergranular corrosion in the condition supplied (solution-annealed), it can set in after welding or when used at high temperatures. It exhibits good corrosion resistance in natural environmental media (water, rural and urban atmospheres) in the absence of significant chlorine and salt concentrations. 1.4301 is not suitable for applications involving contact with seawater, nor is it suitable for use in swimming pools.

Material no. 1.4307 (AISI 304L)

Stainless austenitic chrome-nickel steel

As a component not in contact with the medium (e.g. union nut on the tapered closure piece).

Due to the low carbon content of 1.4307, there is basically no tendency to form chromium carbides or the associated chromium-depleted zones. The material is much more resistant to intergranular corrosion compared to grades with a higher carbon content, such as 1.4301. 1.4307 exhibits good corrosion resistance in natural environmental media (water, rural and urban atmospheres) in the

absence of significant chlorine and salt concentrations. 1.4307 is not suitable for use in or around swimming pools. Resistance to reducing acids is limited by low concentrations or temperatures.

Material no. 1.4401 (AISI 316)

The corrosion resistance of 1.4401 is significantly better than that of stainless steel grades 1.4301 and 1.4307, particularly when chlorides are also present, thanks to the addition of 2 - 3% molybdenum.

1.4401 has excellent corrosion resistance in natural environmental media (water, rural and urban atmospheres), as well as in industrial sectors with moderate chlorine and salt concentrations, in the food industry and the agricultural food sector.

Due to its relatively high carbon content it must be taken into account that 1.4401 is not resistant to intergranular corrosion.

Furthermore, it should also be pointed out that 1.4401 is not resistant to sea water.

Material no. 1.4404 / 1.4408 (AISI 316L)

The corrosion resistance of 1.4404 is significantly better than that of stainless steel grades 1.4301 and 1.4307, particularly when chlorides are present, thanks to the addition of 2–3% molybdenum.

1.4404 exhibits excellent corrosion resistance in natural environmental media (water, rural and urban environments), as well as in industrial sectors with moderate chlorine and salt concentrations, in the food and pharmaceutical industries and in the agricultural food sector. Due to its low carbon content 1.4404 is even resistant to intergranular corrosion after welding.

1.4404 is not resistant to sea water!

Material no. 1.4430

Austenitic TIG welding rod for similar types of stabilized and non-stabilized CrNi and CrNiMo steels, particularly in chemical plant construction. Resistant to heat and scaling up to 800 °C, and can be used with wet corrosion up to 400 °C. Not sufficiently resistant to nitric acid attack.

Used for base materials including: 1.4404; 1,4435 and 1.4571.

Material no. 1.4435 (AISI 316L)

1.4435 has excellent corrosion resistance in natural environmental media (water, rural and urban environments), in industrial sectors with moderate chlorine and salt concentrations, as well as in the food industry and the agricultural food sector. In addition, this grade is also resistant to various acidic media. As this material is also resistant to intergranular corrosion after welding, it complies with the following standardized test procedures:

DIN EN ISO 3651-2

The higher proportion of molybdenum in 1.4435 compared to 1.4404 makes it significantly more resistant to reducing acids and chloride media.

Material no. 1.4568

Due to its strong work hardening properties, NIROSTA® 4568 is used for objects that are subject to increased mechanical stress. These include springs that must retain their good elastic properties at temperatures up to 350 °C (662 °F).

NIROSTA® 4568 is supplied in the final annealed condition or in the work-hardened, spring-hardened condition. The material exhibits high strength properties in the work-hardened as well as in the strain-hardened and tempered condition after additional pickling and passivation, combined with satisfactory corrosion resistance.

Negative effects on corrosion resistance include the presence of acids, strong alkalis, ammonium compounds, chlorides and chlorine compounds.

Material no. 1.4571 (AISI 316Ti)

1.4571 has good resistance to corrosion in most natural waters (urban and industrial), provided that the concentrations of chloride, salt, hydrochloric acid and organic acids are low to medium. 1.4571 has excellent corrosion resistance both in the food and beverage industry, as well as in the agricultural food sector.

As this grade is also resistant to intergranular corrosion after welding, it complies with the following standardized test procedures:

DIN EN ISO3651-2

Notes



Armaturenwerk Hötensleben GmbH

Schulstr. 5 – 6
D-39393 Hötensleben, Germany

Telephone: +49 39405 92-0
Fax: +49 39405 92-111
E-mail: info@awh.eu
Website: <http://www.awh.eu>

