

TANKO® CP2S

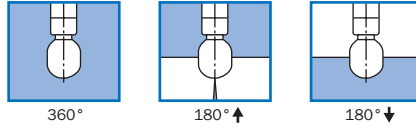

The TANKO® CP2S is a slow-rotation jet cleaner.

With cleaning performance between the TANKO® S series and the jet cleaners of the TANKO® JM series, the TANKO® CP2S is a low-cost solution for effectively cleaning vessels with diameters of up to 4 m. With its slow and even rotation and strong impact, the TANKO® CP2S is suitable for cleaning vessels with strongly adhesive contents.

The TANKO® CP2S is a plain bearing system with a simple structure containing few moving parts. With its low servicing requirements, the TANKO® CP2S provides a compact and reliable solution for cleaning tasks with different cleaning medium and a large temperature range.

All consumption specifications are for orientation only.
The dimensions listed are in mm and are nominal dimensions.

Technical Parameters

Spray angle:	360°, 180° upwards, 180° downwards
Materials:	1.4401 (316), 1.4404 (316L), PTFE (FDA-compliant)
Connections:	3/4" BSP or NPT female thread, clipon for pipe outer-Ø 25.4 mm
Operating pressure:	Cleaning medium: 3 - 12 bar/43.5 - 174 psi
Working temperature:	Cleaning medium: max. 95 °C / 203 °F
Ambient temperature:	Inside the container: max. 140 °C / 284 °F Outside the vessel: min. -20 °C / -4 °F, max. +40 °C / 104 °F
Sterilization temperature:	121 °C / 250 °F for a short time
Volume flow rate:	2.5 - 6.1 m ³ /h / 41.7 - 101.7 l/min / 11 - 26.9 gpm (US)
Rotation speed:	2 - 30 rpm
Weight:	1.1 kg
Range:	Cleaning radius: max. 2 m / 6.6 ft; wetting radius: max. 2.9 m / 9.5 ft
Installation position:	vertically suspended (other positions possible with reduced service life of the plain bearings)
Min. installation opening:	Ø 48 mm / 1.89 in

Dimensions

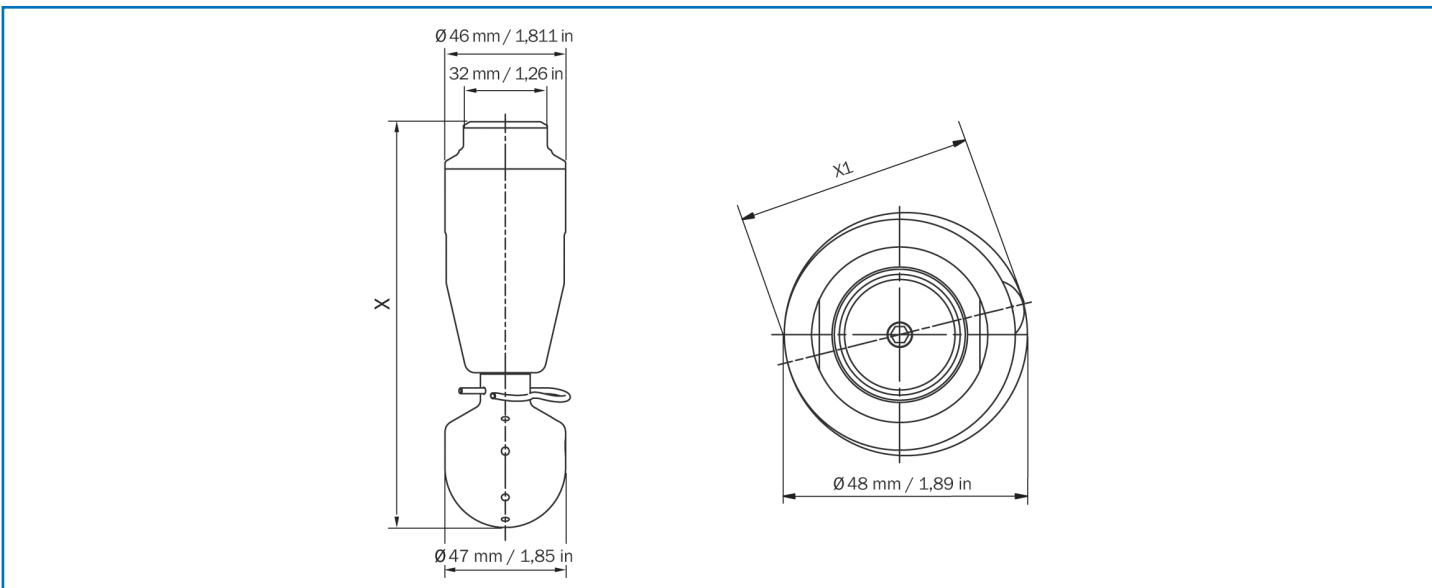

X – approx. 155 mm / 6.102 in (thread) / ca. 165 mm / 6.496 in (clipon)

X1 – approx. 47.4 mm / 1.866 in

TANKO® CP2S

Consumption and Throw Length Data

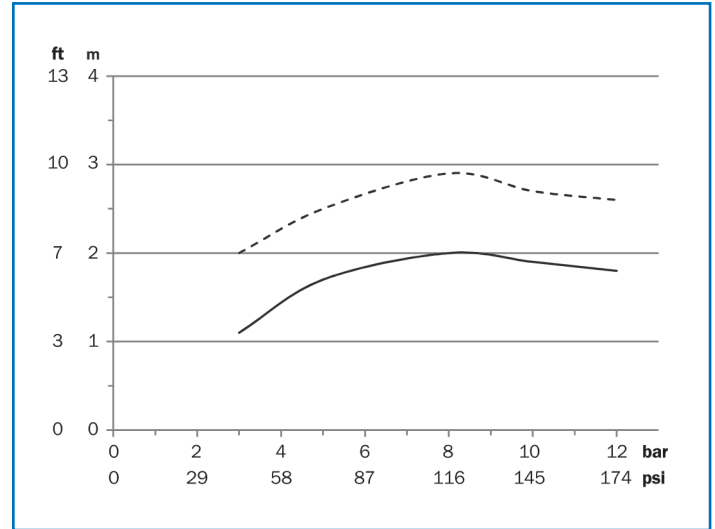
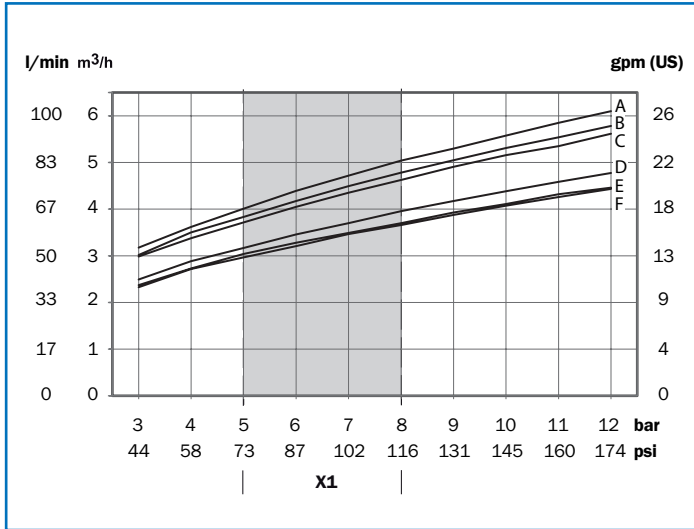

- A - 360° clipon
- B - 180° upwards clipon
- C - 180° downwards clipon
- D - 360° thread
- E - 180° top thread
- F - 180° bottom thread

--- Wetting radius — Cleaning radius

X1 - recommended operating pressure

Ordering Information

TANKO® CP2S

Article No.	Connection	Spray angle	Price/EUR
669 S17 800 132 0	3/4" BSP (female thread)	360°	550.00
669 S17 800 142 0	3/4" NPT (female thread)	360°	550.00
669 S19 100 112 0	Clipon for pipe outerØ 25.4 mm	360°	550.00
669 S17 800 232 0	3/4" BSP (female thread)	180° upwards	550.00
669 S17 800 242 0	3/4" NPT (female thread)	180° upwards	550.00
669 S19 100 212 0	Clipon for pipe outerØ 25.4 mm	180° upwards	550.00
669 S17 800 332 0	3/4" BSP (female thread)	180° downwards	550.00
669 S17 800 342 0	3/4" NPT (female thread)	180° downwards	550.00
669 S19 100 312 0	Clipon for pipe outer Ø 25.4 mm	180° downwards	550.00

Spare Parts and Services

Spare Parts

Article No.	Description	Price/EUR
669 010 00V 000 0	Wearing Parts Packages for TANKO® CP2 and TANKO® CP2S	95.00
664 0C0 121 012 0	Clipon connection set Gr. 04, short	20.17

Material Certificates

Description	Net price/EUR
WAZ 3.1 - EN10204 - TANKO® CP	55.00